

I. APPLICATION

Proxy

Q1. Representing Competitors

Are there any restrictions placed on the Japanese patent attorney with respect to simultaneously representing competitors in overlapping areas of technology?

If not, do the patent attorneys have an obligation to notify their foreign clients of such conflicts of interest?

A1. There is a restriction.

BENRISHI (patent attorney) - The Patent Attorneys Law Art. 31 provides that a case should not be accepted which may have a conflict of interest with another case being represented. However, simultaneous representation is allowed if the parties concerned give consent to the patent attorney.

The Patent Attorneys Law Art.31 applies equally to foreign clients, who should be notified and whose consent is required when a patent attorney wants to represent simultaneously competitors in overlapping areas of technology.

Q2. Pro Se Application

Does the Japan Patent Office (JPO) permit pro se applications? That is, is it permitted for an inventor to file and prosecute his or her own patent application without the assistance of a BENRISHI?

A2. The JPO permits so-called pro se applications as long as the applicant has his or her domicile or residence in Japan irrespective of his or her nationality. Otherwise, it is not permitted for an inventor to file and prosecute his or her application without the assistance of a Patent Administrator [the Patent Law Art.8(1)]. BENRISHI (patent attorneys) and BENGOSHI (attorneys at law) can be Patent Administrators. Any

person, including non-Japanese, who has his or her domicile or residence in Japan and is an applicant's representative with respect to the applicant's patent, can be a Patent Administrator. The Patent Administrator shall represent the principal in all procedures and in a suit instituted against measures taken by an administrative agency in accordance with the Patent Law or an order or ordinance thereunder [the Patent Law Art.8(2)]. However, "resident abroad", that is, the applicant can limit the scope of powers of attorney.

As an exception, if the applicant has a Patent administrator, the applicant (or in case of a legal entity, its representative) is able to proceed before the JPO during his or her stay in Japan without the assistance of a Patent administrator (Art.1 of the Enforcement Ordinance under the Patent Law).

Another exception is admitted when a PCT application filed in the U.S. or other foreign countries designating Japan enters into the Japanese national phase (the Patent Law Art.184-11 applies). In this case, the resident abroad is allowed to proceed before the JPO on condition that the resident appoints a Patent Administrator within 3 months after the expiration of 30 months from the priority date for the filing of a translation of the PCT application, or within 3 months from the day when a request for examination is filed within the above-described 30 months.

Formality

Q3. When Corporate Nationality Certificate Cannot be Notarized

It is now recognized that in some the U.S. states, such as California, Notary Publics can only attest that the person signing the form is that person. A Notary Public cannot legally notarize Corporate Nationality Certificates. How can we properly obtain Corporate Nationality Certificates that will satisfy the Japanese requirements?

A3. The contents of the corporate nationality certificate should be certified by the corporate representative and the statements should be sworn before a notary. Please refer to the attached form. This certificate satisfies the Japanese requirements.

In some the U.S. states where a Notary Public cannot attest corporate nationality, a valid Corporate Nationality Certificate can be obtained by having the certificate certified by the corporate representative before a Notary Public and having the notary notarize the sworn certificate.

However, please be advised that normally the notification for a corporate citizenship is not requested in the Power of Attorney for filing applications. It is required by the JPO only when the applicant name does not show whether the applicant is a corporation or not. For example, when the applicant name includes "Corp.", "Inc.", etc., the corporate citizenship is not necessary, because these words can verify that the applicant is a corporation (or a legal person).

CORPORATION NATIONALITY CERTIFICATE

I hereby certify that the undermentioned is a corporation duly organized under the laws of the State of United States of America having its principal place of business at and that who signed the above power of attorney is a representative of the said corporation and is authorized to execute such documents on behalf of the said corporation.

Name:

Title:

Corporate Name:

United States of America

State of: ss:

County of:

Sworn and subscribed before me on day of , 20 .

(Notary Public)

Seal

Q4. Electronic Filing

Can applications be filed electronically?

A4. Yes, applications can be filed electronically. There are three ways to file an application.

- 1) Paper filing: To submit a set of filing documents to the JPO;
- 2) On-line filing through ISDN line: To send data of filing documents through a special cable network (ISDN line) from a computer terminal to the JPO's host-computer; and
- 3) On-line filing through the Internet: To send data of filing documents through the Internet, using "the Internet application software".

The method 3), i.e., on-line filing through the Internet, became available in October 2005. In order for one to file an application through the Internet, he or she needs to obtain an electronic certificate for security reasons.

On-line filing through the Internet is done by using the Internet application software, which is downloadable from the JPO's website.

Though it may be technically possible to file an application from overseas, an applicant who resides outside of Japan is not allowed to directly file the application through the Internet from overseas (see Q2.). On the other hand, an applicant who resides in Japan but temporarily outside of Japan may file the application from overseas, if he or she obtains the electronic certificate in Japan, and all the other electronic environments such as those referred to the above are set.

Q5. Filing in English Language

Can you file a Japanese application in English to obtain a filing date and later file the Japanese translation? (the U.S. practice allows this practice)

A5. Yes, we can file a Japanese application in English to obtain a filing date.

The JPO started accepting English language applications on July 1, 1995. The specification, drawings, and abstract can be in English, but other bibliographic information has to be in Japanese.

A Japanese translation must follow within 1 year and 2 months from the priority date. The examination and grant of a patent are done in the Japanese language.

However, even if errors are later found in the Japanese translation, they can be corrected based on the original English text.

The English text cannot be amended in any way.

If new matter is introduced in the Japanese translation beyond the disclosure of the English text filed with the JPO, the addition of such new matter will be a reason for rejection and a ground of invalidation.

Q6. Coloring Design Application

Design applications include color (and pattern) as a distinguishing element. How is that shown on applications?

A6. Colors can be applied to a drawing by painting, or color photographs can be used instead of a drawing.

As a rule, color is always a distinguishing element under the Design Law (a law separate from the Patent Law) because no article in reality is without color. However, pattern or shape or a combination thereof without color can be registered as a design. If no color is specified and drawings are prepared in black and white, it is normally understood that the design has a single color which is not specified.

The Design Law requires that a design should consist of shape, pattern or color, or a combination thereof (Art.2 of the Design Law). In other words, a design can consist of shape, of shape and pattern, of shape and color, or of shape, pattern and color. Color should be shown using colors which do not fade

in time.

Specification and Claims

Q7. Missing "Object"

If you do not include "objects" in a patent application, is such action detrimental to the prosecution of the application or later interpretation of the patent?

A7. (1) Under the former provision of the Patent Law Art.36(iv) which applies to patent applications filed on or before June 30, 1995, the answer is yes, that is, the omission of "objects" is detrimental.

The former provision of the Patent Law Art.36(iv) stipulates that the detailed explanation of the invention shall state the "objects"...of the invention in such a manner that it may easily be carried out by a person having ordinary skill in the art to which the invention pertains. Furthermore, under Examination Manual 25.01A, it is required that the "objects" of the invention should be divided into three items proceeded by headings "Industrial Field of Utilization", "Prior Art", and "Problem that the Invention is to Solve".

Consequently, the inclusion of "objects" in a patent application is essential to the prosecution of the application or later interpretation of the granted patent.

(2) Under the revised provision of the Patent Law Art.36(iv) which applies to patent applications filed on or after July 1, 1995, the answer is no, that is, the omission of "objects" is not detrimental.

The revised provision of the Patent Law Art.36(iv) stipulates that the detailed explanation of the invention shall state the invention, as provided for an ordinance of the Ministry of International Trade and Industry, in a manner sufficiently clear and complete for the invention to be carried out by a person having ordinary skill in the art to which the invention pertains.

Furthermore, Art.24-2 of Regulation which applies to patent applications filed on or after July 1, 1995 stipulates that the description in accordance with the regulation as defined in the Patent Law Art.36(iv) shall be made by setting forth the features which are necessary for a person having ordinary skill in the art to recognize the technical significance of the invention, such as the problems to be solved by the invention and the solution therefore or the like.

Therefore, the statement of "object", "constitution and advantage" is not mandatory. The application is not rejected on the ground of mere "omission of object". In other words, the requirement for disclosure can be met, as far as a person having ordinary skill in the art upon filing can clearly recognize the technical significance of the invention from the description of "The Detailed Explanation of the Invention", and can carry out the invention based on the description of "The Detailed Explanation of the Invention".

Q8. Inappropriate "Object"

Can it be detrimental to place an object in an application if later a successful challenge is waged showing that the teachings of the application could not possibly achieve that object?

A8. (1) Under the former provision of the Patent Law Art.36(iv) which applies to patent applications filed on or before June 30, 1995, it is usually detrimental.

Where the teachings of the application can not achieve an object stated in an application upon its filing, it is considered that the claimed invention is incomplete.

Later amendments of the objects could usually be construed as a change of the gist of the invention and eventually such amendments can be refused by the Examiner.

However, if another object is clear or self-evident from the original disclosure of the specification, an amendment to

change the objects to include such an object would not be refused. If the amendment is difficult, such object can be stated in an argument filed in response to an office action without amending the specification.

(2) Under the revised provision of the Patent Law Art.36(iv) which applies to patent applications filed on or after July 1, 1995, the statement of "object" is not mandatory, but stating "object" is not precluded. Therefore, it is possible that an object is placed in an application and later the successful challenge is waged showing that the teachings of the application could not possibly achieve that object. Even in such a case, it would not be detrimental, as far as a person having ordinary skill in the art upon filing can clearly recognize the technical significance of the invention from the description of "The Detailed Explanation of the Invention", and can carry out the invention based on the description of "The Detailed Explanation of the Invention".

Q9. "Problems" and "Advantageous Effects"

With respect to the specification, and the requirement to state "problems" and "advantageous effects", how should "problems" and "advantageous effects" be stated if the invention is simply another or alternative way of doing something, but there is no problem with prior art and the invention does not provide any significantly better efficiency, cost or results?

A9. (1) Under the former provision of the Patent Law Art.36(iv) which applies to patent applications filed on or before June 30, 1995, if no "objects" and "advantageous effects" are stated in the specification, the application will be rejected. In the case mentioned in the question, it is not considered necessary to state "problems". Instead, it is recommended to state "objects" of the invention as providing the alternative method in relation to the prior art. It is also advisable to state the "advantageous effect" as being able to do something without

using the conventional method. In many cases, the alternative method may have some advantage over the conventional method in some manner, which is why the invention was made. It may be helpful if there is an advantage in one aspect, even if there is a disadvantage in another aspect.

(2) Under the revised provision of Art.24-2 of Regulation which applies to patent applications filed on or after July 1, 1995, it is required to state either (i) the problems to be solved by the invention and technical means used for solving the problems, or (ii) the features which are necessary for a person having ordinary skill in the art to recognize the technical significance of the invention. Accordingly, if a so-called "problem-solution approach" is not appropriate, it is not necessary to state "problem." In summary, it is sufficient that explanation is made in such a manner that a person having ordinary skill in the art can recognize the technical significance of the invention.

Under the revised provision of the Patent Law Art.36(iv) which applies to patent applications filed on or after July 1, 1995, statement of "advantageous effect" is not required.

Q10. Several "Advantages"

If there are several advantages, can we avoid including in the claim all the features producing all of the advantages? For example, can we limit the advantages to one, and recite only the features producing that advantage? Can we have two independent claims, each limited to a different advantage?

A10. (1) If there are several advantages, we can avoid including all the features producing all of the advantages and we can limit the advantages to one reciting only the features producing that advantage, which is advantageous in obtaining as broad a scope of claims as possible. A single application can have two or more independent claims, each limited to a different advantage, so long as they meet the requirements of the unity of invention. (Art.37)

(2) Under the former Patent Law which applies to patent applications filed on or before June 30, 1995, the statement of "effect" is required and "specific or unique effect" brought about from the claimed invention should be stated as "effect of the invention".

However, under the revised Patent Law, which applies to patent applications filed on or after July 1, 1995, the statement of "Effect of the Invention" is eliminated from statutory requirement. In stating "effect of the invention" in the specification, it is sufficient that advantageous effect which the invention has as compared with the prior art is stated.

Q11. Claim Format

Is one particular claim format (for example, European "characterized" format, Jepson, etc.) preferred to increase chances of an expanded claim interpretation in subsequent litigation?

A11. There is no particularly preferred claim format.

Even if a Jepson type claim format is used, the technical scope of the claim must be determined with consideration of the preamble, since the preamble constitutes a part of the invention. There is no difference in the scope of protection of claims between different types of claims. There would be no form which is more easily interpreted by the court.

Q12. Dependent Claims

Will dependent claims be automatically determined to be invalid in a trial for invalidation if the independent claim is determined to be invalid?

A12. No.

A trial for invalidation should be demanded for each claim whether independent or dependent, and dependent claims can be maintained if they do not have any reasons for invalidation

themselves, even though the independent claim is determined to be invalid. So, it is recommendable to draft dependent claims if these dependent claims have any additional significant features.

Q13. Unity of Invention

What is the requirement of the unity of invention in Japan?

A13. If all the claimed invention in a single application is linked as to form a single general inventive concept, the application meets requirement of the unity of invention. This requirement corresponds to the rule 13 of the PCT.

More concretely speaking, if two or more inventions have same or corresponding specific technical feature, these inventions satisfy the conditions of the unity of invention. Here, "specific technical feature" means a technical feature apparently contributes to the invention over prior art.

The followings are the examples which satisfy the conditions of unity of invention according to the Examination Guidelines.

(1) If two or more inventions have same specific technical feature, these inventions satisfy the conditions of the unity of invention.

[Example 1]

Claim 1

Polymeric compound A (transparent substance with improved oxygen barrier characteristics)

Claim 2

Food packaging container composed of polymeric compound A

(2) If two or more inventions have corresponding specific technical feature, these inventions satisfy the conditions of the unity of invention.

[Example 2]

Claim 1

Electro conductive ceramic composed of silicone nitride and titanium carbide

Claim 2

Electro conductive ceramic composed of silicone nitride and titanium nitride

[Example 3]

Claim 1

Transmitter provided with time axis expander for video signals

Claim 2

Receiver provided with time axis compressor for video signals received

Claim 3

Transmission equipment for video signals comprising a transmitter provided with time axis expander for video signals and a receiver provided with time axis compressor for video signals received

(3) A "product" and "processes for manufacturing said product, machines, instruments, equipment or other means for producing said product" satisfy the conditions of the unity of invention.

[Example 4]

Claim 1

Foundation pile provided with a bulbous enlargement at its base.

Claim 2

Process for the formation of bulbous enlargement wherein a cavity is formed in the ground using explosives, into which cavity concrete is poured

[Example 5]

Claim 1

Clutch of specific construction X

Claim 2

Process of manufacturing friction clutch of specific construction X

(4) A "product" and "processes of using said product", a "product" and a "products solely utilizing specific properties of said product" satisfy the conditions of the unity of

invention.

[Example 6]

Claim 1

Substance A

Claim 2

Process for killing insects using substance A

[Example 7]

Claim 1

Substance A.

Claim 2

Herbicide composed of substance A

[Example 8]

Claim 1

Compound A (useful as the intermediate of compound B)

Claim 2

Process of manufacturing compound B by reacting compound A with another compound

[Example 9]

Claim 1

DNA X

Claim 2

Process of manufacturing polypeptide A by culturing recombinant microorganism including DNA X

[Example 10]

Claim 1

Fuel burner A provided with a fuel inlet in the direction tangent to a mixing chamber

Claim 2

Process of manufacturing carbon black including a step for allowing a fuel to flow in the direction tangent to a mixing chamber of fuel burner A

(5) A "product" and "processes for handling said product", a "product" and "products for handling said product" satisfy the conditions of the unity of invention.

[Example 11]

Claim 1

Prefabricated house of certain construction

Claim 2

Process for storing and transporting prefabricated houses of certain construction

(6) A "process" and "machines, instruments, equipment or other things directly used in working of the invention of the process" satisfy the conditions of the unity of invention.

[Example 12]

Claim 1

Process for producing concrete products wherein ice granules are mixed into the cement together with aggregate, and then poured into molds

Claim 2

Equipment of certain construction provided with an ice crushing unit and a mixing unit for mixing the crushed ice with cement and aggregate

[Example 13]

Claim 1

Method for measuring water depth comprising certain procedures

Claim 2

Distance measuring equipment of certain construction

[Example 14]

Claim 1

Process of preparing final product Z by oxidizing intermediate A

Claim 2

Intermediate A

Chemical data

Q14. Toxicity Data

a. What is the latest situation regarding the necessity to include toxicity data in the description of an application concerning a pharmaceutical invention?

b. If in fact a pharmaceutical composition is placed into

testing and the specification includes an example which exactly describes the chemical composition and the placement into testing, can the data associated with the example later be added, if it is proven that the example is actual, rather than "paper" or "prophetic"?

A14.a. The past Examination Guidelines (applicable to the applications filed before January 1, 1988), now abolished, stipulated that at least the acute toxicity data should be described in the specification of an application concerning a pharmaceutical invention. However, after that, under the practice, any toxicity test data are not required. Then, the Examination Guidelines concerning the pharmaceutical inventions (applicable to examination to be made on or after April 15, 2006) were published in 2006 and do not require that the specification should describe such toxicity data. Therefore, the practice which does not require to describe the toxicity data in the specification has already been established.

A14.b. No.

The patent practice concerning the pharmaceutical invention is very strict. If the pharmacological efficacy data of the pharmaceutical composition of the example (or the description which is considered equivalent to the pharmacological efficacy data) were not disclosed in the specification at the filing date of the patent application, it is impossible to obtain a patent for the pharmaceutical composition. The addition of the data to the specification after the filing date of the present application is considered as new matter. "Paper" or "prophetic" examples are not considered as the working examples.

Q15. Physical-Chemical Data

What physical-chemical data are required in Japanese applications to support an invention of a composition which is

a mixture of known ingredients?

A15. The physical-chemical data should be usually required in the specification for an invention of a composition. The chemical field is the technical field where the effect of a composition cannot be readily expected based on the components constituting the composition. A composition invention is usually invented for providing a new and useful composition for some intended purpose. Such usefulness is usually proved by the physical-chemical property of the composition relating to such intended purpose. The kind of the physical-chemical property of the composition should vary depending on the kind of the composition. For example, please assume that an adhesive composition has been invented, which provides a stronger adhesive property than the conventional adhesive composition. In order to confirm that the claimed adhesive composition is indeed useful as an adhesive composition, it is natural that the specification should contain physical-chemical data based on which the adhesive strength of the claimed invention can be evaluated.

Q16. Physical data or Test Data of a Compound

a. Assuming that an invention is a chemical compound, are physical data (such as melting points, viscosity, etc.) required for support an invention of a chemical compound?

b. If a herbicidal composition containing such a compound is claimed, are herbicidal test data required?

c. How many examples are necessary?

A16.a. Yes. It is usually necessary for supporting the utility of an invention of a chemical compound. Physical data or test data are useful for proving that the compound was actually prepared and for proving that the compound would be useful for the intended purpose (such as the use of an effective component for a pharmaceutical composition).

A16.b. Yes.

As stated above, the chemical field is the technical field where the effect of a composition cannot be readily expected based on the components constituting the composition. It is usually impossible to expect the property or usefulness of the compound. Therefore, test data concerning the herbicidal effect should be usually necessary for proving an invention of a herbicidal composition.

A16.c. It depends on the cases.

The disclosure of the specification has to enable one skilled in the art to practice the claimed invention. The chemical field is the technical field where the effect of a compound cannot be readily expected from its chemical structure or chemical name. Further, the support requirement is recently strictly evaluated. The support requirement is to evaluate how broadly the working examples justify or generalize the scope of the claimed invention. Therefore, it should be necessary to provide as many examples as possible at the filing date of the application. Generally, of course, at least one representative working example is required to support the chemical compound. If the chemical compound claimed is defined by the general formula covering a generic concept of a compound, which can broadly cover various distinct types of chemical structures from each other (such as an aliphatic group and aromatic group), it should be reasonably necessary to provide working examples for each one of the distinct chemical groups.

Q17. U.S. Application Lacking Data

a. If a U.S. priority application claiming a compound does not have physical or chemical data, will priority be denied for a corresponding Japanese application?

b. If the physical or chemical data were added to the Japanese application, then will priority be denied for a corresponding Japanese application?

A17.a. Yes. The priority may be affirmed. However, it seems that the disclosure of the specification would be considered insufficient in respect of the support requirement or enabling disclosure requirement. As stated above, the chemical field is the technical field where the effect of a compound cannot be readily expected from its chemical structure or chemical name. Without any physical or chemical data, it is considered that the usefulness of the compound cannot be confirmed or it is unclear whether or not the compound can be prepared based on the disclosure of the specification at the filing date of the present application. In this respect, the Japanese application may not be granted as a patent for the lack of support or enabling disclosure.

A17.b. No. The priority should be denied. By adding such physical or chemical data, the invention claimed in the Japanese application would become workable at the filing date of the corresponding Japanese application, as compared with the invention disclosed in the basic U.S. application which is considered as being unworkable under our patent practice. It is considered that the subject matter claimed in the Japanese application, which is workable, is not disclosed in the U.S. application. Therefore, the priority would be denied for the Japanese application. (e.g., Part IV: PRIORITY, 4.2 Examples 4 to 6)

Q18. Paper Examples

In the U.S., chemical patent applications often contain a mixture of examples which have actually been carried out and examples which are prophetic (or "paper") examples. Do "paper" examples improve the acceptability of the Japanese patent application?

A18. No. The "paper" examples do not either improve the acceptability of the Japanese patent application; or create a

specific problem. The JPO does not accept "paper" examples only.

Q19. Prophetic Examples

In Japan, it is acceptable to use prophetic examples?

A19. The same answer is as in Q18. In addition, it is not possible to add to the specification, any data obtained by actually carrying out the prophetic examples, after the filing date of the application, as constituting new matter.

Biotechnology

Q20. Deposit of Microorganism or Biotech Material

Assume the deposit has been made (e.g., plasmid, etc.) in the U.S. with ATCC prior to the U.S. filing date of the U.S. application. The Japanese law requires deposit prior to the filing of the priority application. The U.S. law allows deposit after filing of the application. The Accession Number from the ATCC was not made available until after the U.S. filling of the U.S. case. The Accession Number is therefore not disclosed in the U.S. application as originally filed. Can the Accession Number be added to the Japanese application?

A20. No. The priority cannot be enjoyed for the Japanese application, if the invention is related to the microorganism which were not easily available at the filing date of the U.S. application. In addition, the Accession Number from the ATCC (or any other International Depository Authority under Budapest Treaty, or a storage number when the deposit was made to a reliable public storage authority) cannot be added to the Japanese application even at the filing date of a Japanese application, even if it is desired to retain the convention priority right. Under the current practice, the Accession Number should be described in the basic application to enjoy

the convention priority.

In this connection, the Examination Guidelines regarding microorganism explain a case of exceptionally acceptable supplement as follows:

"An amendment of an accession number of a microorganism is not regarded as addition of new matter, if microbiological characteristics of the microorganism are described in the specification as filed, to the extent that the microorganism can be identified, and deposit of the microorganism can be identified based on the name of the depositary institution, etc. In such a case, the applicant should make an amendment of the accession number without delay." (Part VII: Chapter 2 Biological Inventions, 2.3) If the accession number were added to the basic U.S. application after the filing thereof under the condition stated above, then it may be possible to enjoy the Convention priority based on the basic U.S. application for the corresponding Japanese application.

Q21. Submitting of Sequence Listing

When an application includes an amino acid and/or nucleotide sequence, does the Japanese law require submit the sequence listing? Must the sequence listing in computer readable form be submitted with the application? Can the sequence listing be supplemented after the filing date of the application?

A21. In case where a patent application (including an application claiming the priority of a foreign application and a PCT national phase application) describes an amino acid and/or a nucleotide sequence in the specification and/or figure, the applicant must prepare the sequence listing for the nucleotide and/or amino acid sequence in accordance with "Guidelines for the preparation of specification which contain nucleotide and/or amino acid sequences" and describe the sequence listing in the specification. Furthermore, when the application is filed, the electronic data of the sequence listing in computer

readable form (electronic data) must be submitted.

The submission of the electronic data is made by submitting a floppy disc or compact disc storing the data. When a patent application is filed by using on-line application system, the electronic data can be submitted together with the application.

It is not necessary to submit the sequence listing when the application is filed. However, when no sequence listing is submitted at the filing of the application, the JPO issues a notice of formal objection and requires the applicant to submit the electronic data of the sequence listing within the prescribed term (usually 30 days from the notice). Unless the electronic data are submitted within the prescribed term, the application will be dismissed. Therefore, it is recommendable to submit the sequence listing at the filing of the application.

Q22. Patenting Transgenic Animals

Have there been any decisions on what are "inventions liable to contravene public order, morality or public health"? In particular, is this an obstacle to the patenting of transgenic animals?

A22. At present, the provision regarding public order, morality or public health is not considered to create any problem or question for patentability of transgenic animals in Japan.

There have been some decisions ruled by the Tokyo High Court. For example, a banknote forging apparatus, a vest usable for smuggling gold bars, an opium smoking tool, a man's energy enhancing device, etc. were considered liable to contravene public order and morality. An invention relating to a bingo game machine was considered patentable although the judge recognized that it would be usable for gambling. A specific medicine for cancer and Streptomycin were both considered not liable to contravene public health in spite of the fact that they cause harmful but relievable after-effects when they are administered in large quantities.

A plant breed and an improvement of a breed of animal are patentable in Japan as long as they have novelty, inventive step and industrial applicability, and further they are properly disclosed in the applications so that anyone skilled in the art may easily carry out the inventions. In this connection, many patents regarding an animal itself have been granted in Japan. A Harvard mouse was also granted. No issue was raised in connection with public order, morality or public health.

Divisional Application

Q23. When a divisional application can be filed

a. When can a divisional application be filed in Japan?

b. Can a divisional application be filed even after the expiry of the time period for filing a Request for Examination in its parent application?

A23.a. (1) In the Patent Law, Art.44 regarding a divisional application was amended and has been effective since April 1, 2007. It is applied to not only applications whose parent applications were filed before April 1, 2007, but also those filed on or after April 1, 2007. The time period in which a divisional application can be filed depends on when the parent application was filed. The details are explained below.

(2) In an application filed before April 1, 2007, a divisional application can be filed during the time period when an amendment can be filed (Art.44(1), see Fig.23-A).

That is, the time period is either one of the followings:

(i) Before an applicant receives the first Office Action, the applicant can file a divisional application at anytime;

(ii) After an applicant receives an Office Action, the applicant can file a divisional application within the time period designated by the Examiner to file a written opinion against the Office Action; and

(iii) After a Decision of Rejection is made, an applicant can file a divisional application within 30 days from the filing

date of a Notice of Appeal against the Decision of Rejection.
 (3) In an application filed on or after April 1, 2007, a divisional application can be filed even during the following time period (Art.44(1), see Fig.23-B) in addition to the aforementioned time period, (2) (i) to (iii) allowed for an application filed before April 1, 2007 (Art.44(1)(i));

(iv) After a Decision of Rejection is issued, an applicant can file a divisional application within 30 days from the date when the applicant received the Decision of Rejection, (Art.44(1)(ii)); and

(V) After an application is granted in the examination procedure (not in the Appeal procedure), an applicant can file a divisional application within 30 days from the date when the applicant received the Decision of Grant (Art.44(1)(iii)).

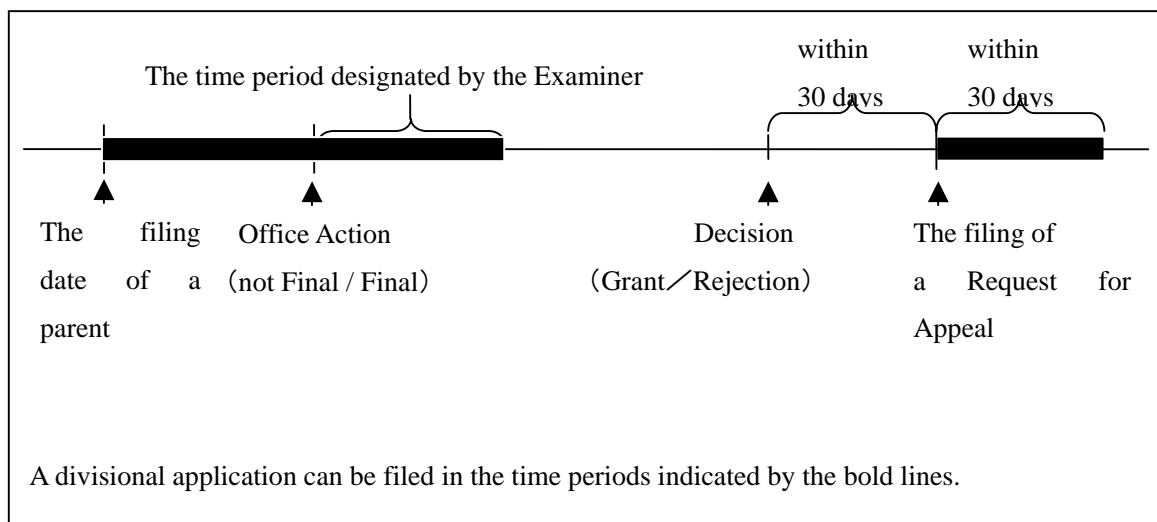

Fig.23-A [In the case of a divisional application whose parent application was filed before April 1, 2007]

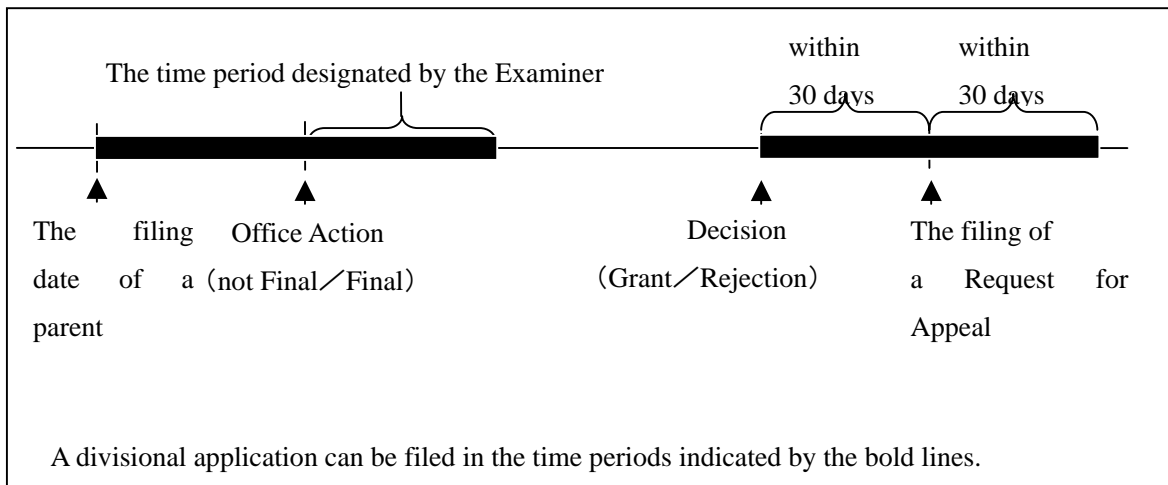

Fig.23-B [In the case of a divisional application whose parent application was filed on or is filed after April 1, 2007]

A23.b. Yes, as long as a Request for Examination for a parent application was filed before the expiry of the statutory time period for filing a Request for Examination (within 3 years from the filing date), a divisional application of the parent application can be filed even after the expiry of the time period for filing the Request for Examination. In this case, an applicant can file a Request for Examination of the divisional application within 30 days from the actual filing date of the divisional application (Art.48-3(2)) (See Fig.23-C).

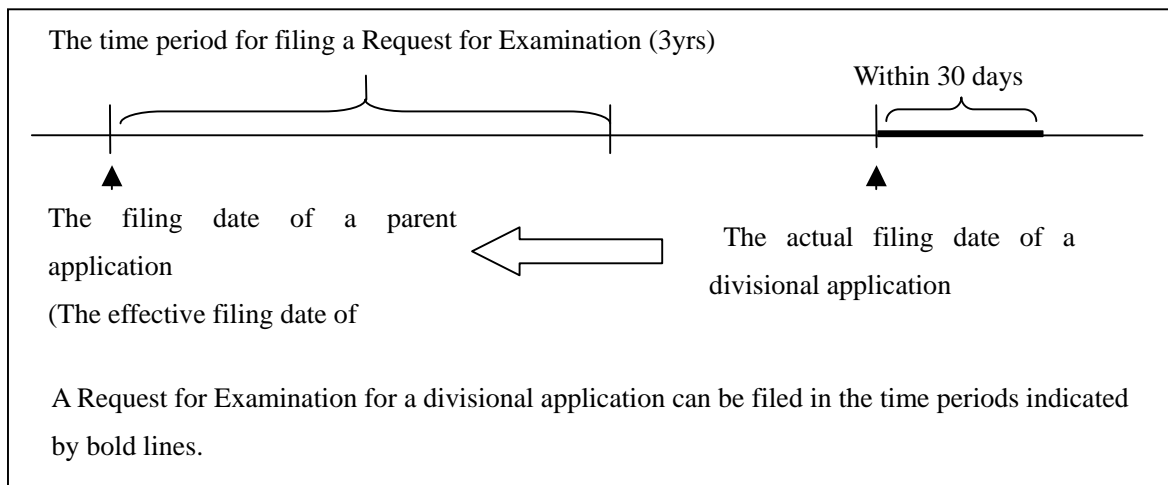

Fig.23-C

Q24. Requirements for Divisional Application

a. What are the other requirements to file a divisional application besides a time period?

b. Besides, what does an applicant filing a divisional application after April 1, 2007 have to pay attention to?

c. In a divisional application, is it necessary to submit a priority document, even though it is submitted in its parent application?

A24.a. (1) In the Patent Law, a divisional application satisfying the following requirements has the benefit in which the divisional application is deemed to have been filed on the filing date of its parent application (Art.44(1)).

i) The parent application includes two or more inventions; and

ii) Only a part of the inventions in the parent application is claimed in the divisional application.

If a divisional application does not satisfy the above-requirements, the divisional application cannot obtain the benefit. In this case, the filing date of the divisional application is the actual filing date of the divisional application.

(2) In the Examination Guidelines issued by the JPO, the above-requirements (1)(i) and (ii) are interpreted as follows:

i) An invention claimed in a divisional application has to be described in the specification and drawing at the time when the divisional application is filed;

ii) (An) invention(s) claimed in a divisional application is/are not all of inventions described in the specification and drawing at the time when the divisional application is filed; and

iii) A divisional application must not include a new matter not disclosed in the original claims, specification and drawings of its parent application.

(3) If a divisional application filed in the time period according to the aforementioned A23.a.(3)(iv) or (v),

the subject matter which used to be claimed in the original specification but not claimed in the last specification immediately before the Office Action or Decision of Rejection cannot be claimed in the divisional application. This is because the subject matter not claimed in the last specification must not be recaptured by any amendments.

A24.b. (1) In the case where a divisional application whose parent application was filed on or after April 1, 2007, even though the Office Action is not made FINAL, there is a case the Office Action is substantially treated as FINAL as follows.

If a reason of rejection notified in an Office Action in a divisional application is the same as the reason already notified in the prosecution in its parent application, even though the Office Action is not FINAL, an amendment for the Office Action is restricted in accordance with the manner of amendment in the case of a FINAL Office Action (Art.17-2(5), 50-2).

(2) Regardless of the filing date of the parent application, an applicant who files a divisional application has to submit a Statement. In the Statement, the applicant has to state:

(i) If the divisional application has a portion modified from its parent application, that the modified portion is substantially included in the description of the original specification of the parent application;

(ii) That the rejection notified in the prosecution in the parent application has been already overcome; and

(iii) That each invention claimed in the divisional application is not identical to any inventions claimed in the parent application.

A24.c. No. As long as documents (e.g. a priority document, a written statement required in the article for exceptions to lack of novelty) are submitted in its parent application, it is unnecessary to submit those documents in the divisional application (Art.44(4)). The documents submitted in the parent application are deemed to be submitted on the actual

filing date of its divisional application.

Q24-2. Conversion to Utility Model Application

Is it possible to file a divisional application as a utility model application from a patent application?

A24-2. Yes. A divisional application filed out of a patent application can be a utility model application by conversion of application. The conversion to a utility model, however, is only possible within 9 years and 6 months from the filing date of the patent application.

Claiming Priority

Q25. Inventors to be included

In filing a Japanese patent application where convention priority is claimed based on two or more earlier U.S. cases, must the Japanese case include all inventors named in all convention cases, even if the claims of the Japanese case do not include contributions by one or more of the inventors named in the convention cases?

A25. The Patent Law does not provide definite guidance as to how to deal with relationship between claims and inventors. For example, in Japan, there is no practice to amend the name of any inventor according to an increase or decrease in the number of claims.

Thus, it seems that the JPO does not concern itself about the decision as to whether to include all inventors named in all convention cases in the case of filing a Japanese patent application, then a discrepancy of inventors between U.S. and Japanese applications does not create any negative result during the prosecution before the JPO. It is correct, however, to include names of all the original inventors into the Japanese application, as far as they contributed to any part of the

claimed inventions of the Japanese application.

Q26. Can omitted Priority be Corrected?

If a claim of priority is omitted when the application is filed, by accident, is there any way to correct such error?

A26. There is no way to correct the error. It is not allowed to add a claim of priority to an application after it has been filed.

In this connection, if the error were found before the expiration of the priority period, it is possible to withdraw the application and refile an application with the addition of the claim of priority, within the priority term of the basic application.

Q27. Claiming Both U.S. and Japanese priorities

Assume the following facts :

The original U.S. application is filed on January 1, 2005 and claims invention "A"; and

The Japanese Convention application is filed on January 1, 2006 and claims priority on the original U.S. application. Then, whether a second Japanese application can be properly filed on January 1, 2007 with claims for inventions A and A' and claim priority on the original U.S. application, and also the first Japanese application?

A27. No, the second Japanese application cannot enjoy the benefit of priority based on said earlier original U.S. application. It can only claim so-called internal priority based on the first Japanese application.

Q28. Hypothetical Case and Discussion

Assume the following factual situation:

a. January 1, 2005 - the U.S. application (US1) is filed

claiming "A";

b. January 1, 2006 - the Japanese application (J1) was filed claiming "A" and claiming priority based on the U.S. application on filed on January 1, 2005 (US1); and

c. January 1, 2007 - A second Japanese application (J2) is filed claiming A and A' ("A'" is added), and claiming priority based on both the U.S. application filed on January 1, 2005 (US1) and the Japanese application filed on January 1, 2006 (J1).

Whether under the Japanese practice, the second Japanese application (J2) noted in "c" above is a proper application?

Time Line

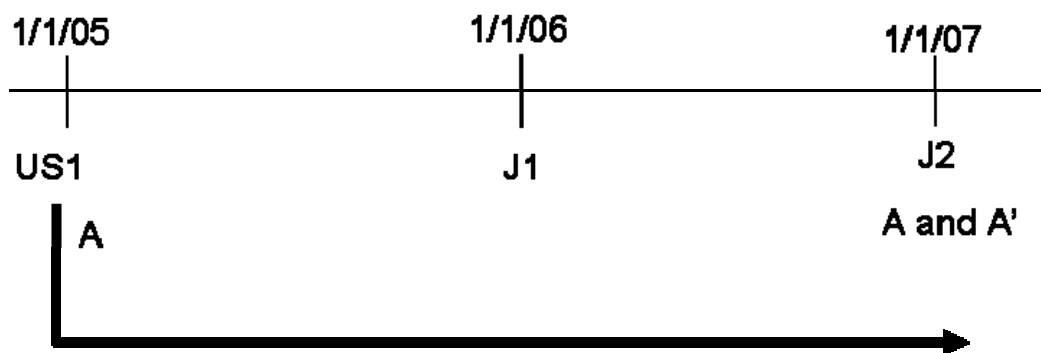

A28. The second application is a proper application as an application. However, the claiming Convention priority may be denied depending on the situation which will be explained below.

(1) With respect to the claimed invention "A" :

First, the U.S. priority based on the U.S. application filed on January 1, 2005 (US1) will be apparently denied in the course of prosecution for the reason that the second Japanese application (J2) was filed more than one year after the priority date [Paris Convention Art.4A(1) and 4C(1)] .

Second, the so-called internal priority based on the first Japanese application (J1) will also be denied for the same reason, because the Patent Law Art.41 prohibits extension or accumulation of the period of priority according to Paris Convention Art.4D(1) .

Third, a patent application is laid open after one year and 6 months from the filing date of the first application or the priority date, if the Convention priority is claimed in the application. Therefore, the first Japanese application (J1) may have already been laid open when the second Japanese application (J2) was filed.

Accordingly, as for the inventive part of the claim "A", the second Japanese application (J2) will be rejected for lack of novelty over the laid-open publication of the first Japanese application (J1).

(2) With respect to the inventive part of the claimed invention "A'":

Depending upon when "A'" is first disclosed in a specification, different results may take place as follows:

(i) If "A'" is first disclosed in the U.S. application filed on January 1, 2005(US1), the invention "A'" will be rejected for the same reason as in the case of "A";

(ii) If "A'" is disclosed in the first Japanese application filed January 1, 2006 (J1), the second Japanese application (J2) can enjoy the benefit of the internal priority; or

(iii) If "A'" is first disclosed in the second Japanese application filed January 1, 2007 (J2), as for the inventive part of the claim "A'", the second application (J2) will be considered and handled as the "first" or "earliest" application.

Q29. Hypothetical Case and Discussion, Continued

Assume the following factual situation (similar to Q28):

a. January 1, 2005 - the U.S. application (US1) was filed claiming "A";

b. A PCT (U.S.) application (PCT) was filed claiming "A" and claiming U.S. priority of January 1, 2005 (US1) (please note that on or after January 1, 2004, when a PCT application is filed, all the member countries are automatically designated);

c. July 1, 2006 - A first Japanese application (J1) was

filed claiming "A" and claiming priority (U.S.) of January 1, 2005 (US1) and PCT of January 1, 2006 (PCT); and

d. July 1, 2007 - A second Japanese application (J2) was filed claiming "A" and "A'", and also claiming priorities based on all of January 1, 2005 (US1), (PCT) of January 1, 2006 (J1) and (JP) of July 1, 2006 (J2).

Whether under the Japanese practice, the second Japanese application (J2) is a proper application?

A29. The second application is a proper application as an application. However, the claiming Convention priority may be denied depending on the situation which will be explained below.

Time Line

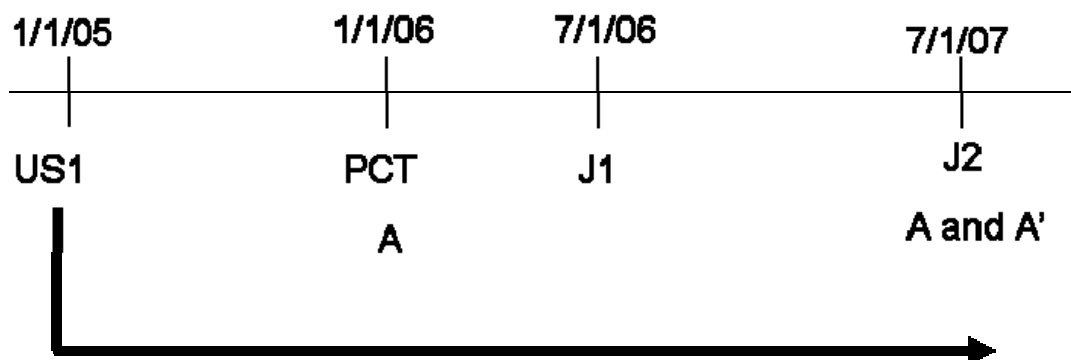

(1) With respect to the claimed invention "A" :

First, all of the priority claims based on the U.S. application (US1), the PCT application (PCT), and the first Japanese application (J1) will be denied in the course of prosecution for the same reason as stated in Q28.

Second, the first Japanese application (J1) may have been already laid open when the second Japanese application (J2) was filed, because the period of one year and 6 months for open-laying the application is counted from the international filing date of the PCT application (January 1, 2006). In addition, the PCT application (PCT) should have been already internationally published when the second Japanese application (J2) was filed.

Accordingly, as for the inventive part of the claim "A", the second Japanese application (J2) will be rejected for lack of novelty over the laid-open publication of the first Japanese application (J1) or the international publication of the PCT application (PCT).

(2) With respect to the claimed invention "A'":

Depending upon when "A'" is first disclosed, different results are expected to take place as follows:

(i) If "A'" is first disclosed in the U.S. application filed January 1, 2005 (US1) or the PCT application (PCT), the invention "A'" will be rejected for the same reason as in the case of "A";

(ii) If "A'" is disclosed in the first Japanese application filed July 1, 2006 (J1), the second Japanese application (J2) can enjoy the benefit of the internal priority;

(iii) If "A'" is first disclosed in the second Japanese application (J2) filed on July 1, 2007, as for the inventive part of the claim "A'", the second application (J2) will be considered and handled as the "first" or "earliest" application.

Internal Priority

Q30. How Internal Priority is Claimed

Is it possible to file a Japanese application (patent or utility model) which claims the priority based on an earlier filed Japanese application (patent or utility model) within the priority year (so-called internal priority period) allowing inclusion of earlier related invention made within the priority year?

A30. Yes, it is possible.

The internal priority system provides an applicant of a Japanese application with the same benefit as enjoyed by those of Paris Convention applications.

A later filed application claiming an internal priority

based on an earlier filed application can protect a fundamental invention as well as its improvements or peripheral inventions. In this case, the invention of the earlier Japanese application is combined with the later filed application as a single application and the earlier filed application is deemed withdrawn after a lapse of 1 year and 3 months (15 months) from the priority date (the filing date of the earlier filed application).

Q31. How Double Patenting is avoided in the case of the Internal Priority?

Where one files a later Japanese application claiming the internal priority based on an earlier filed Japanese application and claiming the same subject matter plus additional subject matter, can one avoid a double patenting rejection by filing of withdrawal of the earlier-filed application?

A31. As stated above, a single application will only be pending, which is the later filed Japanese application which covers the original invention contained in the earlier filed Japanese application and the related improvements or related different inventions contained in the later filed Japanese application. Accordingly, the double patenting rejection should not take place for the internal priority application.

National Phase Entry of PCT Application

Q32. Nationalizing a PCT Application

a. When can a national phase application be filed in Japan?

b. A PCT application was filed in the U.S. Patent and Trademark Office. Please explain the procedure involved in commencing the national phase in Japan.

A32.a. A national phase application must be filed within 30 months from the priority date, irrespectively of the filing of a demand under Chapter II of PCT has been filed.

A32.b. It is required to file a petition for commencing a national phase in Japan and a Japanese translation of each of the specification, claims, abstract and, if any English legends are contained in drawings, those drawings of the international (PCT) application as originally filed.

A translation of an Amendment filed and entered under Art.19 and/or Art.34 of the PCT can also be filed, but this is not mandatory. If the applicant wishes the national phase application to be examined with the amended claims, it should be necessary to submit an English translation of the Amendments under Art.19 or 34 of the PCT.

However, please note that our patent practice concerning the introduction of new matter is very strict. It is recommendable to submit an Amendment when a request for examination is filed, after having carefully reviewed the amendments in respect of whether or not the amended matter would be considered as introducing new matter under our patent practice. By this, you can save unnecessary cost for translation of the Amendments at the time of filing the national phase application in Japan. In addition, you can take into the consideration, any change in technical importance or any new prior art found in relation to the claimed invention up to the time when a request for examination is filed, which situation may affect your claiming in the Japanese application.

The original applicant of the national phase application in Japan must be the inventor(s) or, if the invention was assigned, the assignee(s) who is named in the petition. We recommend, therefore, that when you instruct your Japanese associate to file a national phase application in Japan, you send a copy of the request of the international application together with filing instructions and documents to be translated. A Power of Attorney signed by the applicant is not required when the national phase application is filed.

Utility Model

Q33. Please explain Utility Model System in Japan

A33.

1. History

The Japanese utility model system was established in 1905 as a system to supplement the patent system which was introduced in Japan in 1885. From 1905, the number of utility model applications had always exceeded that of patent applications. However, with the growing technological level in Japan, a reversal occurred in the number of applications in 1980, and the trend continued after that. After the 1993 amendment which adopted a non-substantive examination system for registration, the number of utility model applications decreased rapidly, and the number has remained low since the 2004 amendment (see the accompanying graph chart).

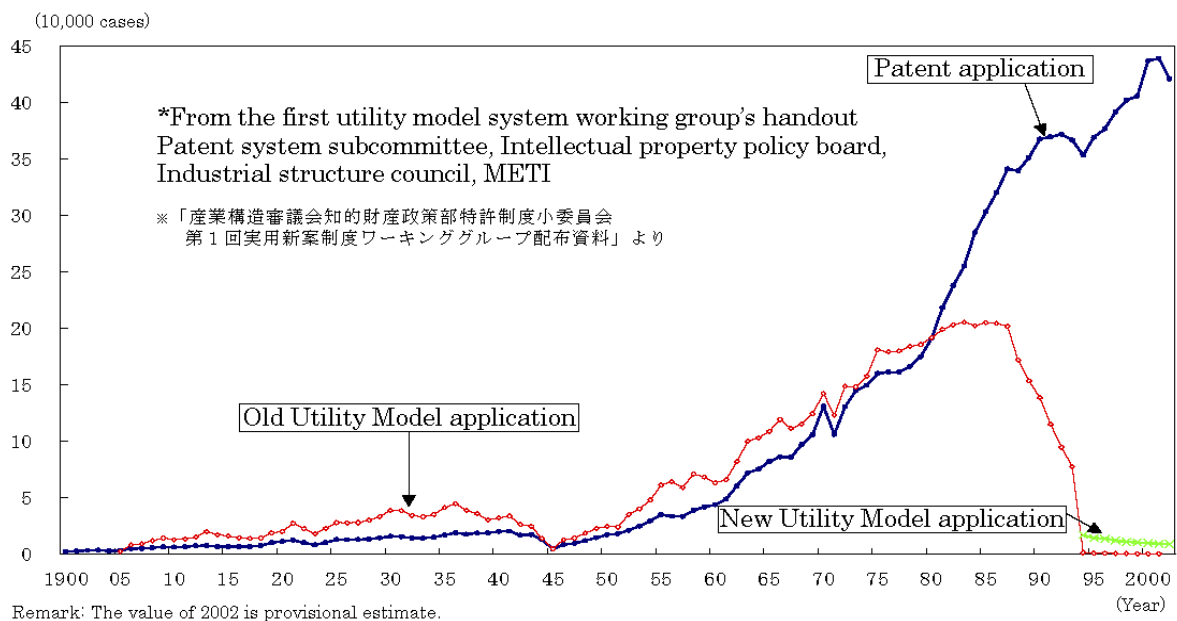

2. Differences between the utility model system and the patent system

Points of difference between them are described below, because both of them are basically the same.

(1) Objects of protection

Both the Utility Model Law and the Patent Law are the same in that the creations of technical ideas are protected, but the objects of protection by the Utility Model Law are limited to technical ideas relating to the shape, structure or combination of an article. Therefore, materials themselves (e.g.: medicines, chemical compounds, glasses and alloys etc.) are not the objects of protection. Further, a method shall not be protected under the Utility Model Law of Japan. However, articles are broadly interpreted in practice in Japan, and thus immovable properties, for example, buildings, bridges, and plants, are also interpreted as articles.

Therefore, the range of technical field of protection under the Utility Model Law is smaller than that of the Patent Law.

(2) Inventive step

The inventive step of the invention needs to be not "easy" (Art.29(2) of the Patent Law), while it is sufficient if the inventive step of the device is not "very easy" (Art.3(2) of the Utility Model Law).

That is, the inventive step of the invention is higher than that of the device.

(3) Procedures for application

All the utility model applications should be accompanied by drawings (Art.5(2) of the Utility Model Law), because an object of protection is limited to the device of an article. Further, the annual fee for each year from the first to the third year shall be paid in a lump sum, simultaneously with the filing of the utility model application.

(4) Fee

Fees for a utility model application and registration are lower than fees for a patent application and registration.

(5) Examination

A utility model right is granted only after the examination of formal and basic requirements except substantive requirements (e.g. novelty and inventive steps etc), so that a non-substantive examination system is adopted in the Utility Model Law. Therefore, if a utility model application satisfies

the formal and basic requirements, the application will be registered. However, if it does not satisfy the substantive registration requirements, it shall be disputed in an appeal for invalidation (Art.37 of the Utility Model Law). It is noted that a utility model application will be registrable in about 4 months from the filing date, while a patent application will be registrable for in about 27 months from the date of request for examination (as of 2006).

(6) Amendment and Correction

The applicant may file amendments only for one month from the filing date or a period specified by the Commissioner.

Further, the owner of a utility model right shall be entitled to one opportunity to correct the description, claim(s) for utility model registration or drawing(s) attached to the request, excluding the prescribed cases (Art.14-2(1) of the Utility Model Law).

However, only where correction has as its objective the cancellation of claim(s), the owner of a utility model right may correct the description, claim(s) for utility model registration or drawing(s) without limitation for the time or number of times, excluding after the notification of the conclusion of trial examination (Art.14-2(7) of the Utility Model Law).

(7) Term of right

The term of the utility model right is 10 years from the filing date of the application (Art.15 of the Utility Model Law), while the term of patent right is 20 years from the filing date (Art.67 of the Patent Law).

(8) Exercise of right

Basically, a utility model right is the same as a patent right in the exercise of right, but it is different from the patent right in that the utility model right may be exercised only after giving a warning in the form of a report of a technical opinion as to registrability of the utility model in order to avoid abuse of the right (Art.29-2 of the Utility Model Law).

However, where the owner of a utility model right has exercised his or her utility model right or given a warning to

an infringer, and a trial decision that the utility model registration is to be invalidated has become conclusive, such owner shall be liable to indemnify any other party with respect to any damage caused to that party by the exercise of that right or by the giving of the warning (Art.29-3(1) of the Utility Model Law). The reason, therefore, is that the technical opinion is a kind of nonbinding comment of the Japan Patent Office.

Any person may make, to the Commissioner of the JPO, a request for a technical opinion (Art.12 of the Utility Model Law). The request may be made even after the expiration of the utility model right except when the registration has been invalidated in a utility model invalidation trial. It takes about six months from the date of request to get the technical opinion.

3. Accommodation between utility model system and patent system

(1) A utility model application may be converted to a patent application and vice versa. Especially, a utility model application may be converted into a patent application within 3 years from the filing date of the utility model application only during the pendency of the case before the JPO.

(2) The owner of a utility model right may file a patent application on the basis on his or her utility model registration (Art.46-2 of the Patent Law). However, in such a case, the owner shall abandon his or her utility model right in order to avoid double examination.

4. Practical tips

Utility model rights are not stable so that the Utility Model Law adopts the non-substantive examination system. Therefore, Japanese companies, especially big companies, are reluctant to use the utility model registration system (see the graph chart noted in the foregoing).

Fees

Q34. How Official Fees are determined for Claims?

A34. Official fees are required for filing an application, a request for examination, and annuities.

The official fee for filing the application is a fixed amount.

The official fee for request for examination and an annuity are calculated based on the number of the claims.

Q35. How much would be a Japanese patent attorney's charge to a client for filing a patent application?

A35. The JPAA (Japan Patent Attorneys Association)'s standard price on services by a Japanese patent firm has been abolished since 2001. Therefore, there is no fixed amount for attorney's fee. The attorneys should previously discuss with the clients and make an agreement on the attorney's fee.

Cost Items for filing application:

1. Application for patent*1
- 1'. Application for patent with English language text
2. Disbursement for preparing drawings, if any
3. Claiming Convention priority(ies)
4. Electronic filing of application by on-line transmission

Note*1:

For foreign clients, we usually receive an English text for the patent application. Therefore, this cost item should mainly cover the translation cost. The translation cost (JPY/words) may vary depending on the attorneys. It may be usually about JPY200,000 to JPY500,000 for typical cases. This cost item usually includes the docketing fee, besides the translation fee.

In this connection, for the domestic clients (mainly

small-medium size enterprises), the JPAA surveyed an average price by way of questionnaires published in 2003.

According to the survey, assuming that one patent application has a specification of 15 pages, 5 claims, 5 drawings, and 1 page of abstract, wherein no translation work is included, the application cost for 80% of the cases surveyed is JPY250,000 to JPY350,000.

Others

Q36. Non-Inventor's Application

Is there a 35USC102(f) equivalent in Japan, which would prevent someone from filing an application on someone else's invention? For example, suppose Party A discloses an invention to Party B under a non-disclosure agreement; before Party A can file its application, Party B files an application on A's invention, claiming it is B's.

a. Is B's patent valid?

b. What procedures are there in JPO for Party A to contest allowance of Party B's patent?

c. How are the rights of Party A protected? Can Party A file its own application after Party B; will Party B's application be an Art.29-2 reference? Can Party A file a civil trial to have the ownership rights under Party B's application and patent assigned to Party A?

A36.a. Party B's patent is not valid. The patent application filed by a person who is not an inventor and has not duly succeeded to the right to obtain a patent for the invention concerned is to be rejected under Art.49(6). Usually, however, such a fact is not known to an Examiner in charge. Therefore, the application will not usually be rejected for that reason under the examination procedure. Then, Party B's application may be granted. The patent, however, is not valid.

Under the situation, if Party A were aware of the fact that Party B has filed an application for the invention, Party

A should submit an observation to that effect that the Part B's application should not be patented with any necessary documents proving such fact.

A36.b. After grant, it is possible to invalidate such a patent through an invalidation trial. See Art.123(6).

It may be usually difficult to contest allowance of such patent by submitting evidence of such a fact in the course of the examination by an Examiner stage.

However, by way of an invalidation trial, evidence of such a fact and argument could be reasonably considered by the Trial-Examiners so as to fully consider the fact under Art.123(6).

A36.c. Party A Should file his or her application as soon as possible, before Party B's application is laid open to the public. In such a case, Party A can get his or her patent as if Party B's application does not exist, because Party B's application is regarded as being originally invalid. Party B's application cannot be an Art.29-2 reference. Party B's application can be an Art.29-2 reference against a later application other than Party A's, if Party B's application were laid-open to the public.

If, however, Party A's application should not be timely, Party A permanently loses his or her chance to get a patent under his or her own name, because after laid-open publication of Party B's application, the invention has become publicly known and it is too late to file a new application.

Party A cannot get the ownership rights under Party B's application and no assignment of a patent to Party A would be possible. Civil trial can be filed to confirm the ownership of Party A, but not for assignment of Party B's application or patent to Party A.

Q37. "Time" vs. "Day" of Application

A37. Whether or not the claimed invention is novel is determined by the time of "filing of an application" for such invention (Art.29(1)). Theoretically, even if the application is filed on the same day as the publication of an invention by a third party, but the application is filed before the publication of the invention on the same day, then the claimed invention is novel over the publication. The Examination Guidelines (Part II, Chapter 2, "Novelty and Inventive step") state as follows (1.2.1).

1.2.1 Prior to the Filing of the Patent Application

"Prior to the filing of the patent application," not stating "prior to the date of filing of a patent application," implies the definite time even in hours and minutes of the filing.

Consequently, the invention filed is deemed publicly known in Japan prior to the filing of a patent application, for instance, when the application is filed after noon on the date while the invention in question is publicly known before noon on the same date in Japan. The invention filed is deemed as having been described in a distributed publication in foreign countries prior to the filing of the patent application, when the application is filed after noon on the date in Japan while the publication is distributed in foreign countries before noon on the same date (Japan local time).

Practically, when the receipt of a patent application by the JPO is recorded not on the time, but on the date. Any publication having the same date as the filing date of the application is presumed by the JPO to have been known (distributed to the public) no earlier than the filing of the application, unless any evidence to traverse such a presumption is submitted (Examination Manual, 42.06A). In the case where a publication was distributed on the same day as the filing date of the application (or priority date), it is necessary to determine what time it was actually distributed in order to reject the application.

In this connection, where the invention is published on a given day in, e.g., a British scientific journal published

in London at 1 p.m. GMT, and where the U.S. priority application is filed by Express Mail in San Francisco at 12 Noon PST (PST is 8 hour delay from GMT), well after the close of business in London, is novelty lost because of the different time zones? In this case, novelty may be probably be lost if the above situation is well proved.

II. PATENTABILITY

Novelty; Publication

Q38. Definition of "Publication"

Suppose the inventor provided a written disclosure of an invention to a customer in the U.S. without confidentiality obligation. What factors determine whether this disclosure would be considered as a "publication", and therefore a bar to a Japanese Patent Application?

A38. Art.29(1)(iii) is interpreted as follows:

A "publication" refers to information transmitted by a medium such as documents, drawings or the like, which have been copied for the purpose of disclosure to the public by way of distribution. According to this definition, for example, a microfilm or a floppy disk may be a media for "publication". Moreover, for there to be a "publication", it is not necessary to make an actual copy.

The term "distributed" means that the publication is placed in a situation where any person having no secrecy obligation has access to the publication. At present, the secrecy obligation/restriction can be made unilaterally by the proprietor of the information. An agreement of the obligation/restriction need not be explicit, but may be understood by virtue of the circumstances of the disclosure or the practice in the scientific, academic, or industrial community. A further disclosure that does not provide for the

same obligation/restriction would not be effective as a publication, since the further disclosure would be in breach of the original obligation/restriction.

The "invention which was described in a publication" refers to an invention which can be recognized from the descriptions in the publication and matters equivalent thereto.

Here, "equivalent matters" are intended to include things that can be recognized from an explicit description, in light of the state of the art on the date of the publication and the knowledge of a person having ordinary skill in the art.

Further, note that in Japan the invention described in a publication published just prior to the date of the application can always anticipate the invention of the application.

Therefore, the "written disclosure" mentioned in the question satisfies the above definition and constitutes a bar to a Japanese patent application, as long as it is written to extent that persons skilled in the art can recognize the invention at the time the application was filed.

Q39. Disclosure through the Internet

Is a disclosure through Internet considered as a publication?

A39. Information disclosed through the Internet is not considered as a publication, since it is not distributed or stored in a media such as a microfilm, a CD-ROM and a floppy disk.

However, under the current Patent Law, Art.29(1)(iii) includes information made available to the public thorough the Internet as well as a publication.

Here, "made available to the public" means that the web page describing inventions is linked from other web pages on the Internet or is placed within the search engines and the web page is not inaccessible to the public.

Like a publication, information disclosed through the

Internet can be a bar to a Japanese Patent Application without a need of proving the fact that the information was actually known to somebody. If the date when the information was posted on the Internet is proved, the information can act as a bar to the allowance of claims in a Japanese Patent Application, which was filed after the proved date.

Q40. Definition of "Distributed"

In Art.29(1)(iii), does the term "distributed" include single copy of a thesis or document in a library in a foreign country?

A40. The term "distributed" in Art.29(1)(iii) is understood to mean that the publication is placed in a situation where any one or more persons who are not subject to any restriction on subsequent use or disclosure has access to the publication. The Japanese courts appear to take a more liberal view: even if a document had not been copied yet but could have been copied upon request, it is regarded as a publication under the Law (Supreme Court decision rendered on July 4, 1980, Torikeshishu, 1980, p.83). See Q5.

Therefore, the answer is YES.

As previously noted, a restriction on "distribution" that avoids a "publication" may be unilateral or even understood within the practices and policies of a particular group. The restriction need not be legally enforceable, but may be found to exist so long as it is based on a recognized practice or understanding. Thus, there would be a sufficient restriction where the document is available in a university or government library that restricts access to enrolled students and faculty, or to government and industry representatives, even though such persons could distribute the information widely to interested persons within their organizations who also have a right of access.

Q41. Date of "Publication" of a Paper Submitted to a Journal

Would a paper submitted for consideration by a professional journal be a "publication" as of the date it is submitted to the journal (i.e., before the journal actually prints the paper)?

A41. No. The actual distribution date of the journal is considered to be the publication date.

Q42. Distribution of a Paper for Evaluation before Printing

If the journal distributes copies of the paper to a committee of professionals for evaluation (before printing of the paper), is this a publication?

A42. A committee of the above type is normally supposed to be a closed one where the information disclosed there should be kept confidential. Accordingly, the distribution to such committee might not be considered to be a publication unless there is an explicit rule that the information disclosed there can be disclosed to public.

Novelty; Presentation, Display, Sale

Q43. Oral Presentation

If an oral presentation describing an invention is made at a conference of specialists in Japan, is the event considered to be one where the invention is publicly used or known in Japan?

A43. If the specialists do not have any confidentiality obligation with respect to the invention, the oral presentation will constitute an event that results in the invention becoming publicly known or used. On the other hand, if the specialists are actually obligated to keep the invention secret under certain regulations or if they are deemed to be most likely obligated to do so, it does not constitute an event resulting

in public knowledge or public use in Japan. The obligation can be cultural or institutional, based on established practice or procedure, and need not be legally enforceable.

Q44. Overseas Presentation Before Japanese Nationals

If presentation is outside of Japan but there are Japanese nationals at the conference, is the event considered to be one that results in the invention becoming publicly used or known in Japan?

A44. The term "publicly known or used" was restricted to events occurring within the jurisdiction of the Japanese law until December 31, 1999; however, from January 1, 2000, "publicly known or used" was expanded to cover worldwide events. That is, a presentation made outside Japan did not result in an invention becoming publicly used or known, regardless of the presence of Japanese nationals, up to December 31, 1999; but from January 1, 2000, the term "publicly known or used" is not restricted to events occurring within the jurisdiction of Japanese Law and, an overseas presentation falls within the definition "publicly used or known". Accordingly, it is no longer meaningful to discuss whether or not presentation is in the jurisdiction of the Japanese Law or Japanese nationals are in attendance.

Q45. Display at an International Trade Show

What is the effect on novelty of a display at an international trade show?:

a. Non disclosing demonstration [secret process, resulting product is displayed]; or

b. Fully disclosing demonstration.

A45.a. The term "publicly known" is interpreted as a condition under which the person observing the information can understand the technical contents of that invention in question. Thus the

process, which is kept secret, will be considered as novel. Note that an offer of sale of an invented product constitutes an infringement if the invention is patented. However, the offer of sale does not necessarily mean that the patented product has been disclosed to the public and therefore does not necessarily destroy novelty.

A45.b. Ordinarily, a fully disclosing demonstration in Japan will destroy novelty, provided that a person who actually receives the information can understand the contents of the invention technically. Thus, where the person receiving the information is not sufficiently skilled to understand the disclosure, even though other highly skilled persons who did not see the demonstration could have understood the information, there is no novelty-destroying event.

Q46. Selling; a Product Made by a Secret Process

What is the effect of selling a product made by secret (undiscoverable) process on the ability to obtain a Japanese patent on (a) the process; and (b) the product?

A46. a) The process remains patentable.

b) One should consider whether or not the product may be specified and its content understood by known analytical methodology before the filing date of the patent application. Judgment as to whether or not a certain analytical method is known to one of ordinary skill at the time the application was filed is determined by the Examiner. If the features of the product can be understood by known analytical tools, the features embodied within the product become unpatentable. Otherwise, the product can keep novelty.

It is further noted, in the case of a patent for a process of manufacturing a product, the coverage of the patent right of that process extends to any product manufactured by such a process. On the other hand, a claim to a product made according to a novel process would not be patentable if the product itself

had previously been disclosed, assuming that the former product is identical to the latter product. Accordingly, it should be understood that the novelty is recognized only in the novel process. In this regard, the former product can be patented if the claimed product has any feature, which can differentiate itself from the latter.

Grace Period

Q47. Inventor not residing in Japan

Can an inventor not residing in Japan take advantage of the 6-month grace period for filing his or her patent application in Japan after the inventor makes a presentation of his or her invention in a printed document?

A47. Yes. It makes no difference if the inventor resides in Japan or not, and also if the inventor has a nationality of Japan or not. Procedures necessary to take advantage of the grace period are as follows [the Patent Law Art.30(1) and (4)]:

(1) The patent application must be filed in Japan within 6 months from the date on which the inventor makes the presentation of the invention, even when the application claims convention priority;

(2) A written statement to seek protection by the grace period must be submitted simultaneously with the filing of the application; and

(3) A certificate proving the fact of the presentation of the invention must be filed with the JPO within 30 days from the filing date.

If the application is filed as a PCT international application designating Japan, the applicant can also enjoy the benefit of the 6-month grace period as long as the PCT application is filed within 6 months from the presentation of the invention [the Patent Law Art.184-14]. In this case, the written statement and the certificate must be submitted to the JPO within 30 days after expiration of the 30-month period from

the priority date (or within 30 days from the date on which a request for examination is filed, when the request for examination is filed within the 30-month period).

Q48. Prior art within Grace Period

Is a document which is published within the 6-month grace period cited as prior art?

A48. Yes, in principle. The provisions for the grace period in Japan give exception to lack of novelty of invention regarding the fact which satisfies certain requirements (the Patent Law Art.30). A document which is published after that fact, which is deemed as exception to lack of novelty, and before filing of a patent application, constitutes prior art for the patent application.

However, exception to lack of novelty of invention can be applied regarding one or more facts. If the publication of that document satisfies the certain requirements (e.g. an author of the document is the same as the inventor of the patent application) and the applicant follows necessary procedures, the publication of that document is also deemed as exception to lack of novelty, and therefore that document is not cited as prior art.

Q49. Definition of "Presentation in a Printed Publication"

What is the definition of a "presentation in a printed publication" which can be deemed as exception under the Patent Law Art.30(1)? Does a publication of patent application qualify? How about a presentation of invention to a single customer?

A49. According to a Supreme Court Decision handed down November 10, 1989, the "presentation in a printed publication" under the Patent Law Art.30(1) has to be made by one having a right of obtaining a patent in Japan (e.g. an inventor or assignee) by

his or her own initiatives. The decision held that a publication of patent application, irrespective of by the JPO or other patent office or organization, does not qualify as "presentation in a printed publication" under the Patent Law Art.30(1) because such presentation is not made by the one having a right of obtaining a patent in Japan by his or her own initiatives.

The definition of "presentation" in the Patent Law Art.30(1) is interpreted as an act of disclosure to others without any obligation for secrecy. Then, the definition of "printed publication" under Art.30(1) would probably be the same as "publication" under the provisions for novelty requirement Art.29(1). According to the Examination Guidelines, a "publication" is information carrying media such as documents and drawings which have been copied for the purpose of disclosure to the public by way of distribution.

Therefore, it would be immaterial whether the presentation is made to a single customer or a plurality of customers. When the presentation of invention to one or more customers is made with obligation for secrecy, the invention does not lack novelty by the presentation (i.e. there is no need to take advantage of the grace period). Even when the presentation of invention to one or more customers is made without any obligation for secrecy, oral presentation does not qualify under Art.30(1). Irrespective of obligation for secrecy, it will be a rare case that the presentation to one or more customers meets the requirement of the "presentation in a printed publication" since a document or drawing used for the presentation to one or more customers is not "copied for the purpose of disclosure to the public by way of distribution".

Q50. Presentation on the Internet

Can the grace period be enjoyed for the presentation of invention on the Internet?

A50. Yes. In this case, a certificate proving the fact of the

presentation of invention on the internet should include (1) an internet address (URL), (2) a date on which the invention is presented on the internet, (3) a name of a person or entity who makes the presentation of the invention on the internet, and (4) explanation to identify the invention. In order to prove the fact including the items (1) to (4) by objective evidence(s), a printed copy of a webpage including the items (1) to (4) is generally required. Furthermore, a certificate by one who is responsible for information on the webpage is also required, except that the website is highly unlikely to be suspected on its credibility.

Q51. Lack of Novelty outside Japan

Can the grace period be enjoyed for the presentation of invention conducted outside of Japan? If yes, questions are the following.

a. Is such presentation a statutory bar for a patent application in Japan, if a Japanese application claims a convention priority based on a foreign application which has been filed within 6 months from the presentation?

b. Is such presentation a bar to a valid Japanese patent?

A51. Yes, the grace period can be enjoyed for the presentation of invention conducted outside of Japan. The presentation can be made any language including English as well as Japanese. When a certificate proving the fact of the presentation includes a document written in non-Japanese language, translation into Japanese should be submitted.

A51.a. A presentation conducted outside of Japan is a statutory bar for an application in Japan unless the Japanese application is made within 6 months from the date of the presentation. Claiming a convention priority based on a foreign application which has been filed within 6 months from the presentation does not qualify the applicant to enjoy the benefit of the grace period.

A51.b. When the situation in Question b is overlooked and a Japanese patent is granted, the presentation will be a ground for invalidation.

Whole Content Approach

Q52. Date considered; In re Hilmer Doctrine

In the case of a rejection under Art.29-2 (Whole Content Approach), is the foreign priority date of the earlier filed application considered, or only the Japanese filing date (i.e., does Japan have an In re Hilmer Doctrine)?

A52. The foreign priority date of the earlier filed application is considered as an effective date for applying Art.29-2 (Whole Content Approach). The Hilmer doctrine is not applied in Japan.

Chemical invention

Q53. New Compound as to Which Way of Functioning is Unknown

If an inventor discovers a new compound that is effective for treating a disease but, does not know how it works, would a claim to the compound be rejected if there is no description of the mode of operation of the compound?

A53. In the case where a new compound is being claimed, it would be sufficient to describe a fact related to the applicability and effect of the compound treating a disease. It is not necessary to clarify the mechanism (in the chemical reaction, biological reaction, or the like) of expressing such effect by the compound.

However, in order to demonstrate the effect (efficacy data) of the compound for treating a disease, at least one working example would be required, even though it may be done by in vitro experiments.

The application, therefore, will not be rejected on this

point.

Q54. Second Purpose of a Known Pharmaceutical

Assume that a pharmaceutical composition known to be useful for a first purpose is found to be useful for a second purpose, but there is no difference in the pharmaceutical composition. Can this invention be patentable in Japan?

A54. Yes, the invention is patentable. A claim may have the form:

"A pharmaceutical composition for treating (combating) disease X (second purpose) comprising a compound Y as an active ingredient."

The novelty of a pharmaceutical invention is judged from the two viewpoints; one is the compound contained in the composition. The second is the pharmaceutical use (e.g., The Tokyo High Court Judgment of April 25, 2001 (Heisei 10(Gyo Ke)401) etc.). Therefore, even if there is no difference in composition from a known pharmaceutical composition and if the second pharmaceutical use is clearly different from the first pharmaceutical use, the pharmaceutical composition can be patentable for the second use. For example, however, if the second use is the species of the first use, then the second use would not be distinguishable from the first use. In addition, if the second use can be derived from the first use (asthma treating composition vs. a bronchodilatation composition), then the novelty of the second invention would be denied.

Q55. Sale of a Chemical Composition in the U.S.

a. Is the sale of a chemical composition in the U.S. a novelty bar to subsequently claiming the composition in Japan?

b. Does it make any difference whether one can analyze the composition?

A55.a. Usually Yes. The novelty may be denied. For example,

if the composition can be analyzed, the chemical composition can be understood and known and accordingly, the invention of the chemical composition is considered to be publicly worked or publicly known. Therefore, the novelty would be denied (Art. 29(1)(ii)). In addition, with the enforcement of amendments to the Patent Act in 2000, we cannot be entitled to obtain a patent for the invention that was publicly worked in a foreign country.

A55.b. Yes. If the compound cannot be analyzed, the composition cannot be known. Therefore, the novelty would not be denied.

Q56. Industrial Utility of an Intermediate

With respect to the requirement for industrial utility, is an invention for an intermediate or a catalyst considered to be industrially utilizable, and accordingly, be patentable?

A56. An intermediate has utility in being an ingredient of a final product. If the final product has an industrial utility, the intermediate is also regarded to have an industrial utility as a substance for producing the useful final product and therefore is patentable.

Q57. Rejecting a Later Filed Application

a. When an earlier filed patent application discloses subject matter, for example, a chemical compound, without a physical property or anything to show that the compound was actually prepared, is that disclosure sufficient to prevent a later filed application from claiming that same compound, where the second filed application is filed before publication of the first filed application and does make a disclosure of a physical property and the successful preparation of the compound?

b. What if the second filed application was filed after publication of the first filed application?

A57.a. In order for the first filed invention to have the effect of excluding a later application, the disclosure of the first filed application concerning the first filed invention should be that the first filed invention is described in the disclosure of the first filed application so that it is clear that a person skilled in the art could have produced it if the invention is a product and have used the process if the invention is a process, based on the disclosure of the first filed specification and the technical common knowledge at the filing date of the first filed application. (Examination Guidelines, Part II, Chapter 3, "Art.29-2", 3.2(2) and Part II, Chapter 2, "Novelty and Inventive step", 1.5.3(3)). For example, in a case where the specification of the first filed application discloses a chemical compound by way of its chemical structure or its name, if the specification does not disclose the compound so that it is clear that a person skilled in the art could have prepared it based on the disclosure even by taking into consideration the technical common knowledge at the filing date of the first filed application, then the disclosure of the first filed application cannot be cited against the later filed second application. This situation is also true for the case where the second filed application was filed after the first filed application were laid open to the public. In such a case, the laid-open publication of the first filed application cannot be cited as the prior art against the novelty of the second filed application. However, in this case, please note that the laid-open publication of the first filed application may be citable against the second filed invention in view of an inventive step.

a. The novelty (the enlarged novelty under Art.29-2) of the second filed invention would not be denied, unless the compound could have been prepared based on the disclosure thereof even in view the technical knowledge at the filing date of the first filed application.

In this case, more specifically, the above case could be classified into the following subcases depending on what information is disclosed in the specification of the first filed

application, in addition to "a chemical compound" and should be studied, separately.

(i) The specification of a first filed patent application discloses a chemical compound only.

(ii) The specification of a first filed patent application discloses a method for manufacturing the compound sufficiently to enable a person skilled in the art to prepare the compound.

(iii) The specification of a first filed patent application discloses a method for manufacturing the compound insufficiently for a person of skill in the art to judge whether he or she can produce the compound according to the disclosed method.

(1) In the case where the second filed application is filed before the publication of the first filed application which has the disclosure of the case (i). The novelty of the second filed application would not be denied, unless it is clear that a person skilled in the art could have prepared and used the compound based on the disclosure of the first filed application in view of the technical common knowledge at the filing date of the first filed application.

However, the compound itself would have been known if it could be manufactured even though the method for manufacturing the same is not disclosed in the specification of the first-filed application.

(2) In the case where the second filed application is filed before the publication of the first filed application which has the disclosure of the case (ii).

The answer may vary depending on the situation. There would be two responses among the Examiners.

One approach is strict. In this case, the Examiner would judge that, even though the method would enable the manufacturing of the compound, the specification of the first filed application is deemed not to confirm by experimental data that such method for manufacturing enables the manufacturing as long as there is no disclosure that a physical property or anything to show that the compound has been prepared. Therefore,

the novelty of the second filed application is not still denied.

The other less strict approach is to judge that as long as the method which would have enabled the manufacturing is described in the first filed application, the first filed application is enough to deny the novelty of the second filed application even though there is no physical property or anything to show that the compound has been prepared. Because it can be literally said that "the method would have enabled the manufacturing as defined in the regulation (Practical Directive)".

Taking the strict one or taking the less strict one is within the Examiner's discretion and an individual Examiner would consider the novelty depending on the case, taking into account the actual disclosures in the two applications, as well as the technical knowledge at the filing date of the first filed application.

(3) In the case where the second filed application is filed before the publication of the first filed application which has disclosure of the case (iii).

The novelty of the second filed invention would be much less denied than the case of (2), unless any other enabling method for producing the compound was known at the filing date of the first filed application.

A57.b. In the case where the second filed application is filed after the publication of the first filed application.

The way of judging the novelty of the second filed application would be similar to that in the above cases (1)-(3). However, as stated above, in this case, please note that the laid-open publication of the first filed application may be citable against the second filed invention in view of an inventive step.

Q57-2. Experimental Use

Art.29(1) requires that the invention not be publicly used in Japan prior to the filing of an application therefore.

On the other hand, the exception to the lack of novelty can be enjoyed for an invention which was publicly known by the experimentation (Art.30).

In this case, in order to enjoy this procedure, what "proof" of experimentation is required and what is "experiment"; and does limited testing to determine commercial viability or usefulness qualify for this procedure?

A57-2. "Experiment" under this procedure is an experiment conducted to evaluate only a technical effect of the invention by a person having a right to obtain a patent or any third party asked by the person to do the test on their behalf. Any other experimental use conducted to evaluate the commercial viability of a product or feature of a product does not meet this "experiment".

In establishing "experiment", it is necessary to sufficiently establish the date, place, the person's name conducting the test, and full contents of the test, and further, as the case may be, a certification from a witness attesting the test (Examination Manual, 10.34A).

Q58. JPO Policy on Patenting High Temperature Superconductors

What is the JPO policy on patenting applications of high temperature superconductors like $\text{YBa}_2\text{Cu}_3\text{O}_7$? (The USPTO policy seems to be that a mere substitution of, say $\text{YBa}_2\text{Cu}_3\text{O}_7$ for Nb, in an application is not patentable.)

A58. The JPO will probably apply the same policy as the USPTO.

However, a high temperature superconductor could be patented by satisfying the patent requirements of novelty, inventive step, etc. For example, the following inventions for high temperature superconductors have been patented.

Therefore, even inventions where Nb is replaced by such a high temperature superconductor could be patented.

Japanese Patent No. 1976366, Japanese Patent No. 2723173, Japanese Patent No. 2817869, Japanese Patent No. 2913996,

Japanese Patent No. 3251093, Japanese Patent No. 3291628,
Japanese Patent No. 3332334, Japanese Patent No. 3332350,
Japanese Patent No. 3604939

Software Invention

Q59. Patentability of Software

Can you comment on the patentability of software?

A59.

Definition of Statutory Inventions

Art.2 of the Patent Law defines an "invention" as being a creation of technical ideal utilizing a "law of nature". Then, how should we understand the statutory invention? According to "Part II: Requirements for patentability" of the Examination Guidelines

(http://www.jpo.go.jp/tetuzuki/t_tokkyo/shinsa/pdf/PartII-1.pdf#search='Part%20II%3A%20REQUIREMENTS%20FOR%20PATENTABILITY'), Chapter 1 defines "industrially applicable inventions" prescribed in the first sentence of Art.29, i.e., statutory inventions. Here, instead of precisely defining the statutory inventions, Chapter 1 just listed examples of non-statutory inventions. They are only examples and give us suggestions as to non-statutory inventions, but are not exclusive. The non-statutory inventions listed are:

- (1) Laws of nature as such
- (2) Mere discoveries
- (3) Those contrary to laws of nature
Example:
 - perpetual engine
- (4) Those in which laws of nature are not utilized
Example:
 - business method per se
 - computer programming language
 - gaming rules
- (5) Those not regarded as technical ideas

Example:

- personal skill
- mere presentation of information
- written manual, audio CD, image data, computer program listing
- aesthetic creations

(6) Those for which it is clearly impossible to solve the problem to be solved by any means presented in the claim

Example:

- A bridge bridged between the earth and the moon.

If it is difficult to determine whether or not the claimed invention is statutory in view of the above examples, we had better refer to the Examination Guidelines for Computer-Software Related Inventions, effective as from January 10, 2001, which shows the criteria for determining whether or not the invention is statutory.

According to Chapter 1,2. Requirements for patentability of the Examination Guidelines, the following steps are taken to judge statutory inventions:

(1) Patentability requirements are applied to "claimed inventions".

(2) The claimed invention is identified on the basis of the statement in a claim. In this case, the significance of matters (terms) to define the invention is interpreted taking into consideration the descriptions of the specification (other than claim(s)), drawings and the common general knowledge as of the filing.

The basic concept to determine whether software-related invention constitutes "a creation of technical ideas utilizing a law of nature" is as follows.

(1) Where "information processing by software is concretely realized by using hardware resources", the said software is deemed to be "a creation of technical ideas utilizing a law of nature". (See 3. Examples 2-1 to 2-5 in this Chapter.)

[Explanation]

"Information processing by software is concretely realized by using hardware resources" means that, as a result of reading

the software into the computer, the information processing equipment (machine) or operational method thereof particularly suitable for a use purpose is constructed by concrete means in which software and hardware resources are cooperatively working so as to realize arithmetic operation or manipulation of information depending on the said use purpose.

Since "the said information processing equipment (machine) or operational method thereof particularly suitable for the use purpose" can be said to be qualified as "a creation of technical ideas utilizing a law of nature", where "information processing by software is concretely realized by using hardware resources", the said software is deemed to be "a creation of technical ideas utilizing a law of nature".

Reference: To be qualified as "a creation of technical ideas utilizing a law of nature", a claimed invention must be concrete enough to accomplish a certain purpose. (A technology must possess sufficient concrete means to accomplish a certain purpose and can be practically used, ... so that it is objective.) [Hei 9 (Gyo Ke) 206 (Judgement: May 26, 1999)]

(2) Furthermore, the information processing equipment (machine) and operational method thereof which cooperatively work with the said software satisfying the above condition (1), and the computer-readable storage medium having the said software recorded thereon are also deemed to be "creations of technical ideas utilizing a law of nature".

The actual procedure to judge whether a software-related invention is "a creation of technical ideas utilizing a law of nature" (statutory invention) or not is as follows.

(1) Identify the claimed invention based on the definitions in a claim. When the identified invention does not require special judgment and treatment for software-related inventions in judging whether the claimed invention constitutes "a creation of technical ideas utilizing a law of nature", "Part II: Chapter 1. 'Industrially Applicable Inventions'" shall be referred to. (Note*)

(2) Where information processing by software is concretely realized by using hardware resources (e.g. an arithmetic unit

such as a CPU, a storage means such as memory) in the claimed invention, in other words, when information processing equipment (machine) or its operational method particularly suitable for the use purpose is constructed by concrete means in which software and hardware resources are cooperatively working so as to include arithmetic operation or manipulation of information depending on the said use purpose, the claimed invention constitutes "a creation of technical ideas utilizing a law of nature".

(3) Where information processing by software is not concretely realized by using hardware resources, the claimed invention does not constitute "a creation of technical ideas utilizing a law of nature".

Examples where information processing by software is not concretely realized by using hardware resources

[Example 1]

(Claimed invention)

A computer comprising an input means to input document data, a processing means to process the inputted document data and an output means to output the processed document data; wherein the said computer prepares a summary of the inputted document by using the said processing means.

(Explanation)

It can be said that there exists a flow of information processing of document data on a computer in the order of input means, processing means and output means.

However, since the said information processing to prepare a summary of the inputted document and the said processing means cannot be said to be cooperatively working, it cannot be said that the said information processing is concretely realized. Consequently, the claimed invention does not constitute "a creation of technical ideas utilizing a law of nature", since the information processing by software is not concretely realized by using hardware resources.

[Example 2]

(Claimed invention)

A computer to calculate the minimum value of formula $y=F(x)$ in

the range of $a \leq x \leq b$.

(Explanation)

It cannot be said that the information processing to calculate the minimum value of formula $y=F(x)$ is concretely realized by the fact that the computer is used "to get the minimum value of formula $y=F(x)$ in the range of $a \leq x \leq b$ ". This is because information processing to calculate the minimum value of formula $y=F(x)$ and the computer cannot be said to be cooperatively working by only saying "a computer to calculate the minimum value..." Consequently, the claimed invention does not constitute "a creation of technical ideas utilizing a law of nature", which means that it does not constitute "a statutory invention", since the information processing by software is not concretely realized by using hardware resources.

(Note*) Examples where special judgment and treatment for software-related inventions described above are not required in judging whether the claimed invention is statutory so that judgement can be made by referring to "Part II: Chapter 1. 'Industrially Applicable Inventions'" are given below.

(1) Examples not constituting "a creation of technical ideas utilizing a law of nature".

When the claimed invention corresponds to any one of the "non-statutory inventions" listed in "Part II: Chapter 1, 1.1 Non-statutory Inventions", such as (a) economic laws, arbitrary arrangements, mathematical methods, mental activity; or (b) mere presentation of information such as image data taken with a digital camera, program for athlete meeting made by a word processor, computer program listings, etc.; the claimed invention does not constitute "a creation of technical ideas utilizing a law of nature".

(2) Examples which constitute "a creation of technical ideas utilizing a law of nature".

When the claimed invention concretely performs:

(a) Control of an apparatus (rice cooker, washing machine, engine, hard disk drive, etc.), or processing with respect to the control; or (b) information processing based on the physical

or technical properties of an object (rotation rate of engine, rolling temperature, etc.); the claimed invention constitutes "a creation of technical ideas utilizing a law of nature".

Notes

(1) It should be noted that the invention to be judged is the claimed invention. Therefore, even if an invention wherein "information processing by software which is concretely realized by using hardware resources" is described in the detailed description of the invention or drawings, when the same effect is not stated in a claim, the claimed invention is deemed as "non-statutory".

(2) Even if the current claimed invention does not constitute "a creation of technical ideas utilizing a law of nature", when it can be turned into "a creation of technical ideas utilizing a law of nature" by amending the definition of the claim on the basis of the statements in the detailed description of the invention, it is recommendable that the examiner suggest how to amend the definition of the claim simultaneously when notifying the applicant of the reason for refusal.

(3) It should be noted that the judgement whether the claimed invention is "a creation of technical ideas utilizing a law of nature", should be made interpreting the significance of the matters (terms) to define the invention noting that the category of the invention is irrelevant ("an invention of a process" or "an invention of a product").

(4) When a claimed invention is sought for "a program language" so that it is deemed to be an artificial arrangement, it is not "a creation of technical ideas utilizing a law of nature". (See Part II: Chapter 1, 1.1 (4))

(5) When a claimed invention is sought for "program listings" so that it is deemed to be a mere presentation of information, it is not "a creation of technical ideas utilizing a law of nature". (See Part II: Chapter 1, 1.1 (5) (b))

[Example]

"Computer program listings for multiplication of natural numbers, comprising:

```
var x, y, z, u : integer ;
begin z := 0 ; u := x ;
repeat
z := z + y ; u := u - 1
until u = 0
end."
```

"Structured Data" or "Data Structure"

"Structured data" (including "a computer-readable storage medium having structure data recorded thereon") or "data structure" should be judged based on "2.2.1 Basic Concept" in this Chapter.

Claim Drafting

When drafting claims in the field of software-related inventions, we should make focus on categories of inventions which require special judgment or treatment in examining patent applications relating to software-related inventions.

Categories of Software-Related Inventions

(1) Invention of a process

When a software-related invention is expressed in a sequence of processes or operations connected in time series, namely procedure, the invention can be defined as an invention of a process (including an invention of a process of manufacturing a product) by specifying such a procedure.

(2) Invention of a product

When a software-related invention is expressed as a combination of multiple functions performed by the invention, the invention can be defined as an invention of a product by specifying such functions.

A program or data can be defined in the following manners:

(a) "A computer-readable storage medium having a program recorded thereon" can be defined as "an invention of a product".
"A computer-readable storage medium having structured data recorded thereon" can also be defined as an invention of a product, where processing performed by a computer is specified

by the data structure recorded thereon.

[Example 1] "A computer-readable storage medium having a program recorded thereon; where the program makes the computer execute procedure A, procedure B, procedure C, ..."

[Example 2] "A computer-readable storage medium having a program recorded thereon; where the program makes the computer operate as means A, means B, means C, ..."

[Example 3] "A computer-readable storage medium having a program recorded thereon; where the program makes the computer realize function A, function B, function C, ..."

[Example 4] "A computer-readable storage medium having data recorded thereon; where the data comprise data structure A, data structure B, data structure C, ..."

(b) "A program" which specifies a multiple of functions performed by a computer can be defined as "an invention of a product".

[Example 5] "A program which makes a computer execute procedure A, procedure B, procedure C, ..."

[Example 6] "A program which makes a computer operate as means A, means B, means C, ..."

[Example 7] "A program which makes a computer realize function A, function B, function C, ..."

Notes

(1) Even when an invention is claimed using a term other than "a program", if it is obvious, by taking into consideration the common general knowledge as of the filing, that the invention for which a patent is sought is "a program" which specifies a multiple of functions performed by a computer, the invention shall be treated as "a program".

However,

(a) When a patent is sought for "program signal(s)" or "data signal(s)", since they cannot be classified into a statutory category, namely "an invention of a process" nor "an invention of a product", it violates Art.36(6) (ii) of the Patent Law; and

(b) When an invention is claimed using the terms "a program product" or "a program 'seihin'" (Japanese translation of

'product')", since they use terms whose technical scope are not clear, and thereby causing the technical scope of the claimed invention not to be clear, it violates Art.36(6)(ii) of the Patent Law. However, this is not a case where the explicit definition is provided for such a term in the specification without surpassing the ordinary meaning thereof, and thus the scope of the claimed invention results in clear.

(2) Inventions claimed as "shi-su-te-mu" (Japanese pronunciation of "system") or "hoshiki" (Japanese translation of "system") is deemed to be an invention of a product (see Part I: Chapter 1, 2.2.2.1(3)).

Q60. Getting Allowance of Software Related Inventions

a. How can we improve chances of allowance of software related Inventions?

b. Are pure algorithms patentable?

A60.a. First of all, it is important to draft the claimed invention with considering that the information processing by the software is concretely realized by the hardware resources, so that once the software is loaded into the computer, the computer constructs virtually the information processing machine or the operational method of the machine particularly suitable for specific use purpose by concrete means for cooperatively working the software with the hardware resources to realize arithmetic operation or manipulation of information for that specific use purpose. Since the claims are drafted from the aspect of the cooperation of the software with the hardware resources, the specification and drawings should also be drafted with reference to both the hardware arrangements and the software operations and/or functions, preferably by describing the specific details of the hardware and software arrangements by using block diagrams and flowcharts to the extent that those skilled in the art can easily practice the invention.

Also, please consider the necessity of a recording medium or

computer program, or data structure type claim.

In addition, in order to avoid the rejection under Art.36(4) of the Patent Law, technical terminology, abbreviations, marks, symbols, and so on which are not popular or clearly understood should be defined and explained in, for example, an appended glossary.

It is also recommended that unfamiliar special rules, functions, commands, pseudo code, task blocks of a program, and the like should be defined and explained. However, it should be noted that the disclosure of program listings is discouraged and should not be undertaken unless absolutely necessary to understand the invention; however, submission of a listing as reference material is permitted but such listing is not part of the original disclosure.

Lastly, in order to enhance the possibility of allowance, it is recommended that the multi-claim system be effectively used by considering (1) method and system claims; (2) system and part (combination and subcombination) claims; (3) recording medium claims; (4) computer program claims without a recording medium; (5) data structure claims and (6) claims directed to GUI (Graphical User Interface) functions.

A60.b. Pure algorithms, program listings, and computer programs per se are not patentable, similar to the situation in the U.S. and in Europe. Along this same vein, pure business transactions would not involve patentable subject matter in Japan, just as in the U.S. or in Europe; however, if there can be disclosed and claimed a relationship to technical or hardware aspect, the invention may be patentable.

Q61. Case Law Relied Upon in Deciding Patentability

Is case law relied upon in deciding patentability of software?

A61. Yes, they are relied upon. While there are many court decisions upon which the Examination Guidelines are relied, we

usually referred to the Examination Guideline. The following shows court decisions concerning the patentability of software inventions.

- (1) Hei 9 (Gyo Ke) 206 (Decided on May 26, 1999): Examination Guidelines, Part VII, Chapter 1, 2.2(1).
- (2) Show 60 (Gyo Ke) 126 (Decided on February 12, 1986): Cited in the Office Action in the case of the counterpart of USP5, 193, 056 (Hub and Spoke Financial Configuration).
Hei 17 (Gyo Ke) 10698 (Decided on September 26, 2006): the claims amended twice were not accepted and the claims as filed originally are judged not to be statutory.

III. EXAMINATION

Submission by a Third Party of Relevant Information on the Prior Art etc

Q62. When can the information be submitted?

A62. The information can be submitted at any time including after the patent granted under the 2003-revised patent law.

Q62-2. Who can submit the information?

A62-2. Anyone may submit the information. Submission by anonymity is also possible.

Q62-3. What kind of information can be submitted?

A62-3. Not only information relating to the novelty or inventive step of inventions but also information relating to the lack of specification disclosure requirements and to an amendment including the introduction of new matter, etc. can be submitted.

Q62-4. How is the feedback to the provider of the information done?

A62-4. If requested by the provider of the information, the JPO will inform the provider in writing whether the submitted information has been used by the Examiner in the examination procedure.

Q63. How to inform an applicant of the submission of the information?

A63. The JPO will send a letter informing of submission of prior art under Rule 13-2 to the applicant. If the applicant wants to know what kind of information was submitted, he or she has to request for inspection of files.

Q64. Is the information submission system effected?

A64. Yes, it is. 76% of the submitted information has been used in the examination procedure.

Q64-2. Are there any disadvantages?

A64-2. The provider of the information is not permitted to contact the Examiner. Therefore, the provider cannot add the explanation of the submitted information directly to the Examiner.

On the other hand, when such prior art information was submitted, the applicant will be aware of importance of the claimed invention for the provider.

So, the applicant may try to overcome the possible Office Action based on the submitted prior art.

Once the patent is granted, it will be very difficult to invalidate the patent in the Invalidation Trial based on the same

prior art that was submitted.

Expediting Examination

Q65. "Preferential" Examination vs. "Accelerated" Examination

Which will result in faster examination: "preferential" exam or "accelerated" exam?

A65. The number of submissions of "accelerated" examination in 2005 and 2006 were 6560 and 7663, respectively. The number of submissions of "preferential" examination in 2005 and 2006 were only 18 and 10. So, accelerated examination is more recommended in the Japanese practice.

The preferential examination can be requested in a patent application, for those instances where a third party is working the invention without any authority. Such request can be made after pre-examination (KOKAI) principally by either the applicant of the patent application, or by the third party who is working the invention. By contrast, the accelerated examination can be requested by a patent applicant under the conditions mentioned below as the answer of Q67. Since the preferential examination system and the accelerated examination system are different in spirit, there is no point in discussing which system is faster.

Q66. Effect of Expediting

What is the typical time for receiving an Office Action after expediting an application?

A66. In both preferential examination and accelerated examination, the applicant may expect a first Official Action to be issued in about 2 or 3 months from the submission of the request.

Q67. Requirements for Accelerated Examination

Please explain the requirements for the proof to be submitted

to the JPO in order to qualify for accelerated examination.

A67. (1) In the case of a working-related application

(1.1) An explanation on the state of working which should specify:

(1.1.1) A working-related act;

(1.1.2) The period of time in which the invention has been worked or a date at which the invention is scheduled to be worked (not exceeding 2 years from the date of the Explanation form); and

(1.1.3) The relationship between the invention and the working-related act.

(1.2) A prior art search and comparative explanation which should include:

(1.2.1) The result of the prior art search and a concise explanation of the relevance of each patent, publication or other information uncovered by the search.

(2) In the case of an application having a foreign counterpart application.

(2.1) Indication of the filing of an application in a foreign country or a region;

(2.2) A prior art search and comparative explanation which should include:

(2.2.1) The results of the prior art search; and a concise explanation of the relevance of each patent, publication or other information uncovered by the search.

When the application has a foreign counterpart filed in a foreign Patent Office which adopts the substantive examination procedure, a search report prepared by the foreign Patent Office may be submitted in lieu of the document listed in the item (2.2) and (2.2.1).

(3) In the case of a small and medium-sized enterprise or an individual-related application.

(3.1) Explanation that the applicant is small and medium-sized enterprise or an individual.

(3.2) Description of any prior art that the applicant has already known.

In this case, a prior art search is not required.

Office Action

Q68. Standard of Obviousness or Lack of Inventive Step

In the U.S., for example, Examiner must show a motivation for combining references to reject a claim as being obvious over the prior art. It is believed by some the U.S. practitioners that in the Japanese practice, if it were "conceivable" to combine two or more references at the time of filing (priority date), then the claim is considered obvious (lacking inventive step). Is this understanding correct?

If so, does hindsight play a role in the Japanese Examiner's determination?

If not, can you explain the Japanese standard of obviousness (lack of inventive step)?

A68. According to the current "Examination Guidelines" published in December 2000, it is interpreted that Examiner should not use "hindsight" in determining the obviousness of an invention, although no explicit wording for prohibiting the use of hindsight is found in the Guidelines. In this connection, it is helpful to refer to the previous version of the Examination Guidelines (revised in June 1993), the gist of which the current Examination Guidelines has inherited. Specifically, the previous Examination Guidelines, Part II, Section 2.9(1), states that Examiners are placed in a position of interpreting prior art references after obtaining knowledge of the invention to be examined, so that it would be likely that they might gain the false impression that the disclosures of the references were close to the invention, and as a result might overlook significant technical differences. There is further stated in Part II, Section 2.9(2) that Examiners should be careful not to be biased toward considering that the invention would have been obvious when interpreting the prior art based on the knowledge obtained from the disclosures of the application being examined. Thus, Examiners are cautioned not to make a mistake in interpretation of prior art by using "hindsight".

According to the current Examination Guidelines, in Part II, Section 2.4, the examination of obviousness (or non-obviousness)

should be conducted logically in the light of the disclosure of the cited references and the state of the art when the application was filed. If Examiner has attained logical reasoning that a person skilled in the art could have easily arrived at the claimed invention from the prior art, they judge that the invention is obvious, in other words, the invention has no inventive step.

It may be worthwhile in this context to add that in Japan, commercial success may also be taken into account in determining the patentability of an invention. The text of the Examination Guidelines, Part II, Section 2.8(6), expressly states that Examiner may take commercial success into account as a fact which may support the inventive step or non-obviousness of an invention if the Applicant can persuasively prove that the commercial success was achieved owing to the features of the invention.

Q69. Examiner Considered as Skilled in the Art

Are Examiners in Japan considered to be a person with ordinary skill in the art?

How can we best overcome an insufficiency of disclosure rejection if Examiner doesn't understand the invention?

A69. The current Examination Guidelines defines a person skilled in the art in two different ways.

In determining non-obviousness of the invention, the Guidelines (Part II, Section 2.2(2)) prescribes that a person skilled in the art is a hypothetical person who has a common general knowledge in the art at the time of filing the application and ability to use ordinary technical means for research and development, can exercise ordinary creative ability in selecting materials and changing designs, is capable of comprehending all technical matters in the state of the art at the time of filing the application, and is capable of comprehending all technical matters in the field of technology relevant to the problem to be solved by the invention. Thus, Examiner is not considered to be a person of ordinary skill in the art, but Examiner is supposed to carry out the examination taking the knowledge of such hypothetical person into consideration.

In reading and understanding the description of a patent application, the Guidelines (Part I, Section 3.2(1)) define a person skilled in the art as a person who has an ordinary ability to understand the technology in the art. The description of a patent application shall be written so that the invention can accurately be understood and carried out by those skilled in the art taking into consideration the common general knowledge at the time of filing. Thus, to overcome the rejection based on an insufficiency of disclosure, it would be an appropriate way to submit materials which would be effective to show a common general knowledge which would be of help in understanding the invention based on the disclosures of the application.

Q70. Affidavits to Evidence the Knowledge of a Person Skilled in the Art

Can an Applicant argue, if Examiner rejects an additional example? Should affidavits be submitted to evidence the knowledge of one of ordinary skill in the art?

A70. Under the amendment to the Patent Law in 1993, new matter, which is not described or shown in the original specification or drawings, cannot be added. Accordingly, addition of an example or an embodiment of the invention is not allowed in most cases. According to Art.36(4) of the Patent Law, for the purpose of meeting the disclosure requirement, at least one example needs to be shown. This means that the disclosure requirements are met if the application includes one example which is covered by the scope of claimed invention if the scope of the invention is broad. Therefore, there is no longer any basis for Examiner to reject an application on the ground that a sufficient number of examples are not presented, and thus there would be no need to add an example after the filing of the application.

Q71. Declarations to Support Broad Claims

In the U.S., broad claims can be supported by later filed

declarations. Can broad claims in a Japanese application be supported by later filed declarations showing operability of an invention?

A71. As noted above (Q70), for the purpose of meeting the disclosure requirement, it suffices to disclose only one example which is covered by the scope of the claimed invention. However, Examiner may reject a broad claim based on belief that the claim covers a non-operable portion. In this case, the Applicant may submit test data by a declaration to show operability of the invention.

Q72. After the Maximum Term of Patent

What will the JPO do if prosecution drags on beyond the maximum term allowed for a patent after the filing date?

A72. In the case where prosecution drags on beyond the maximum term (20 years) allowed for a patent after the filing date, the JPO will do nothing.

Q73. Extension of Time for Responding to Office Action

Is it possible to have an extension of time for responding to an Office Action? If so, how long is the extended period of time? Can we file an extension of time more than once? How much does it cost to file an extension of time?

A73. Yes, it is possible to have an extension of time for responding to an Office Action. As of April 1, 2007, you can enjoy the following:

(1) A one-month extension is obtainable by filing a request for extension of time. The official fee is JPY2,100.

(2) It is possible to file a total of three requests, separately or simultaneously. Thus, at most, you can have a three-month extension with the official fee of JPY6,300 in total.

Amendment

Q74. Amending Junior Application to Have it Read on Senior Application (Senior application and junior application)

Can the scope of the claims of a junior application cover ("read on") the practice of the invention as described in the senior application? (Is it a good way of defining allowability of junior application claims?)

A74. It may happen in some cases that the scope of the claims of a junior application cover the practice of the invention described in the senior application. However, since such a practice is disclosed or suggested in the senior application, the junior application will be rejected under Art.29-2 (whole content approach) of the Patent Law.

Therefore, it is not considered to be a good way for defining allowability of junior application claims to cover the practice of the invention as described in the senior application.

Q75. Amending Japanese Claims to Parallel Issued Foreign Claims

Facts: An applicant has a first filed foreign application and a later filed Japanese application claiming priority to the foreign application. The applicant would be ultimately satisfied with the Japanese claims having the same scope as claims that issued in the foreign case.

QUESTION: In that case, is it advisable to amend the Japanese claims when requesting examination to parallel the issued foreign claims? Or should the applicant wait until the Examiner has issued the first Office Action before amending the claims?

A75. It would normally be unnecessary to restrict the claims in a Japanese application to the scope of the issued foreign claims. Examination in Japan is done entirely independently of the U.S. or European or any foreign prosecution. The applicant is not currently obligated in Japan to report any prior art references uncovered in other countries. Therefore, it would be rather wise to try to obtain

a maximum scope of the patent protection in Japan regardless of claims in other countries if a maximum scope of protection is desired in Japan.

We believe that the applicant should wait till the first official action before amending the claims. However, it is quite conceivable that restricted claims would lead to quick issuance of a patent or to a stronger patent in view of a possible Invalidation Trial against the patent after grant, particularly when the prior art references cited in the foreign application are very close references.

Q76. Advantage of Paralleling Issued Foreign Claims

Will the fact that Japanese claims are amended to parallel the issued foreign patent claims be given any weight by the Japanese Examiner?

A76. No. Amending the claims as in the issued foreign patent and informing the Japanese Examiner of the fact do not generally help the application or improve the Examiner's impression about the case. Rather, it is possible to offend the Examiner if the foreign prosecution is given too much weight by the applicant, because the Japanese Examiner is expected to make an independent judgment based on Japanese Examination Guidelines and prior art references uncovered in Japan.

Q77. Further Narrowing the Paralleled Claims

By narrowing the claims to parallel the issued U.S. claims, will the Japanese Examiner require that the narrowed Japanese claims be narrowed even more to be allowed?

A77. Yes, it is possible.

During the prosecution in Japan, there may be a possibility of the narrowed Japanese claims being requested to be amended further for at least one of the following grounds:

- (1) More pertinent prior art may be cited by the Japanese

Examiner and the applicant may find it necessary to introduce further limitations into claims in order to overcome the rejection by the Japanese Examiner; and

(2) The narrowed Japanese claims may be rejected even under the prior art which has already been considered by the U.S. Examiner because of the difference in criteria for the "inventive step" or "unobviousness".

Q78. How is the "New Matter" determined?

A78. An amendment including matters beyond "the scope of features of the description, patent claim(s) or drawing(s) originally attached to the request", in other words, an amendment including a new matter is not allowed (Patent Law Section 17-3(3)).

According to the Examination Guidelines (Part III: Amendment of Specification and Drawings), "matters which are originally disclosed in the specification and the like" includes not only "matters which are disclosed in the specification and the like originally" but also "matters which are unambiguously derivable from the matters originally disclosed in the specification and the like". Here, "the matters which are unambiguously derivable from the matters originally disclosed in the specification and the like" indicate matters which can be recognized by a person skilled in the art without description in the specification and the like originally attached to the request that the matters are clearly derived from matters disclosed in specification and the like in view of technical knowledge available to public at the time of filing the request and considered to be nothing less than disclosed in the specification and the like. The followings are examples described in the Examination Guidelines.

[Example 1]

In a patent application regarding a rotary switch including terminal assembly, it is originally disclosed in a specification that a selector 12 is composed by applying a

conductive plate 14 on insulating plate 13. In a case where it is not originally disclosed in the specification and the like that the conductive plate is made from a copper plate, an amendment of changing "a conductive plate" to "a copper plate" is deemed to be addition of new matter.

(Reason) Even though it is common to use a copper plate as a conductive plate, there is no description about a copper plate. Referring to a technical knowledge known at the time of filing the application, the conductive plate for use in a rotary switch may be assumed to be a plate of metal such as copper, copper alloy, and silver, or may be assumed to be a gilded. If so, it cannot be said that it could be unambiguously derived by a person skilled in the art that the "conductive plate" originally disclosed in the specification indicates a "copper plate".

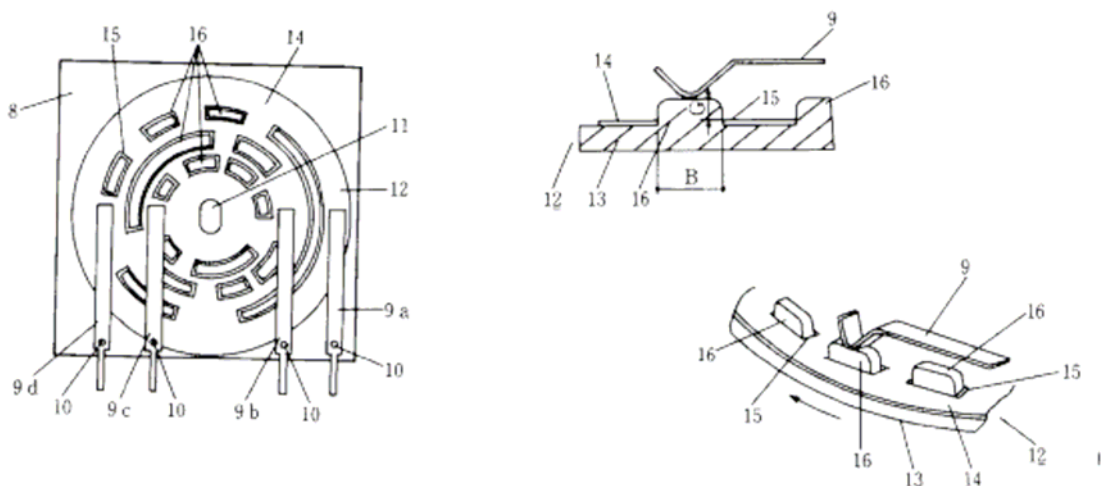

Fig.78-A

[Example 2]

In a patent application regarding a method of drying paddies using a far-infrared ray, an originally filed specification discloses that absorption reaches its peak when the far-infrared ray has a wavelength of $3\mu\text{m}$ or $9\mu\text{m}$, and so a far-infrared ray with these wavelengths is the most effective for drying paddies. Further, from originally filed drawings, it can be read that absorption is over 0.3 when the far-infrared ray has a wavelength between 2 and $3.5\mu\text{m}$ or between 8 and $9.0\mu\text{m}$.

In this case, it leads to addition of new matter if the specification is amended to include "it is effective for drying paddies when the far-infrared ray has a wavelength between 2 and 3.5 μm or between 8 and 9.0 μm , making absorption be over 0.3". (Reason) There is no description regarding setting of a lower limit of absorption effective for drying paddies to be 0.3 in an originally filed specification. Further, it is not recognized that it is clear for a person skilled in the art that the description of the initially filed specification and the like indicated that the lower limit of absorption effective for drying paddies is 0.3.

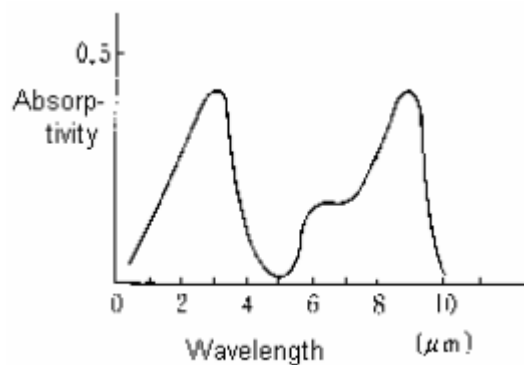

Fig.78-B

[Example 3]

In a patent application regarding a computer, a specification originally disclosed that a signal distributor 20 is set in the middle of an RS232C interface cable connecting a body and a keyboard with each other, and an another I/O device is connected to the distributor 20. Further, it is disclosed in the specification that a printer 5 is connected as an example of the "another I/O device", and an originally filed drawing shows connection of a printer. In such case, an amendment of adding recitation of "other than a printer 5, a mouse which can be controlled by the RS232C interface can be also connected to the distributor 20" leads to addition of new matter.

(Reason) In the initially filed specification, it is disclosed that an another I/O device which can be controlled by the RS232C

interface can be connected by means of a signal distributor. However, a printer, which is merely an output device, is merely described as a specific example. A mouse is well known as an input device, but it cannot be said that it is clear for a person skilled in the art who recognizes the initially filed specification that the "another I/O device" also indicates a mouse.

[Drawings]
FIG.1

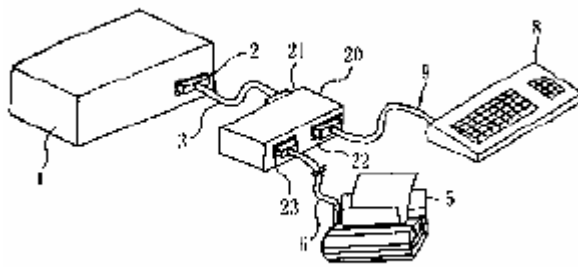

[Drawings]
FIG.1
FIG.2

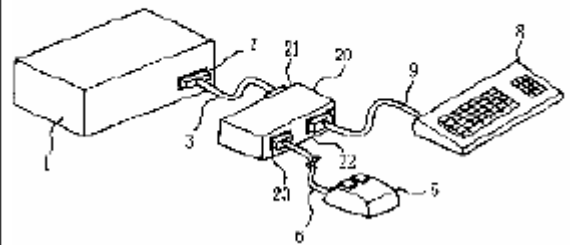

Fig.78-C

[Example 4]

In a patent application regarding a table position controller, it is originally disclosed in a specification that a table (3) is connected to a motor (5) through a feed mechanism, and the position control of the table (3) is made by the rotation control of the motor (5). Further, an originally filed drawing, there is shown a figure which allows a reader to understand that the table (3) is moved by the rotation of the screw (1). In this case, it is allowed to change the recitation of "through a feed mechanism" to "through a screw feed mechanism for linearly moving the table (3) by the rotation of a screw (1)" is allowed.

(Reason) According to the description of the originally filed specification and the depiction of the originally filed drawing, it is recognized to be clear that the one depicted in the drawing is a screw feed mechanism for linearly moving the table by the rotation of a screw.

[Drawings]

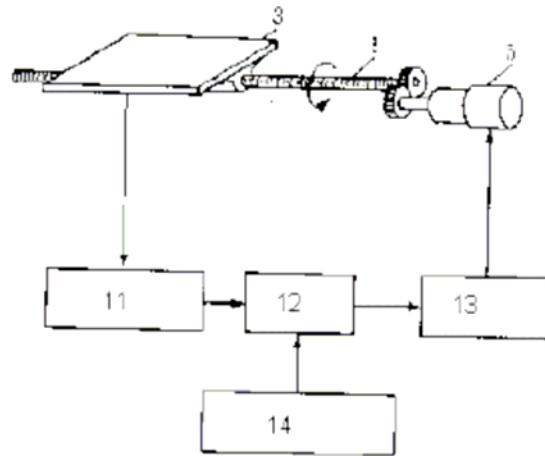

11 position detector
12 comparing device
13 controller
14 target values input device

Fig.78-D

Q79. Please explain the new rule regarding a prohibited amendment which changes the special technical features of invention.

A79. Since the revised patent law in 2006 has come into force, an amendment which changes the special technical features of invention is prohibited (The Patent Law Section 17-2(4)). The expression "special technical features" shall mean those technical features that define a contribution which each of the claimed inventions makes over the prior art. Hereinafter, it will be described with reference to the Examination Guidelines.

Regarding whether or not the amendment is of changing the special technical features of the invention, it is determined based on whether or not all of the inventions examined in connection with requirements for patentability, such as novelty and inventive step, and all of the inventions which are amended satisfy the requirement of unity of invention as a whole.

[Example 1]

[Initially filed claim]

Claim 1: A mobile phone comprising: TV broadcast transmitting/receiving means; and recording means for compressing received TV broadcast data and recording the same.
[Claims after amendment]

Claim (1): A mobile phone comprising: TV broadcast transmitting/receiving means; and recording means for changing compression rate of received TV broadcast data in accordance with contents of the broadcast and recording the received TV broadcast data.

Claim (2): A mobile phone comprising: TV broadcast transmitting/receiving means; and power source controlling means for supplying the TV broadcast receiving means with electric power intermittently during a standby time.
[Commentary]

Here, it will be described about the case where the following references are cited against the initially filed claim during the examination procedure.

Cited Reference 1: It discloses a mobile phone provided with TV broadcast receiving means.

Cited Reference 2: It discloses a mobile information device provided with recording means for compressing and recording image data.

In this case, among the technical features of the invention according to amended claim (1), "a mobile phone including TV broadcast transmitting/receiving means" does not provide a contribution over the prior art in view of the cited reference 1. On the other hand, "a mobile phone including TV broadcast transmitting/receiving means, and recording means for compressing received TV broadcast data and recording the same" provides a contribution over the prior art in view of a common technical knowledge at the time of filing the application and the cited references 1, 2. Therefore, it is a special technical feature.

On the other hand, since the invention according to amended claim (2) does not have the above-described special technical feature, it does not satisfy the requirement of unity of invention with respect to the invention according to

initially filed claim 1. Thus, only amended claim (1) is examined, and an Office Action would be issued with respect to claim (2).

[Example 2]

In an initially filed patent application, the following claims 1-3 were described. The invention according to claim 3 is in the same category as of claims 1, 2 and includes all elements of the inventions according to claims 1, 2. In the examination procedure, it is proven that initially filed claims 1, 2 have no special technical feature, but it is found that initially filed claim 3 has special technical features. With respect to this application, an Office Action is issued which notifies that claims 1, 2 lack novelty and claim 3 lacks inventive step. The claims are amended so as to include claims (1) - (4) having all elements of the invention of initially filed claim 3 and claim (5) not including a part of the elements of invention of claim 3.

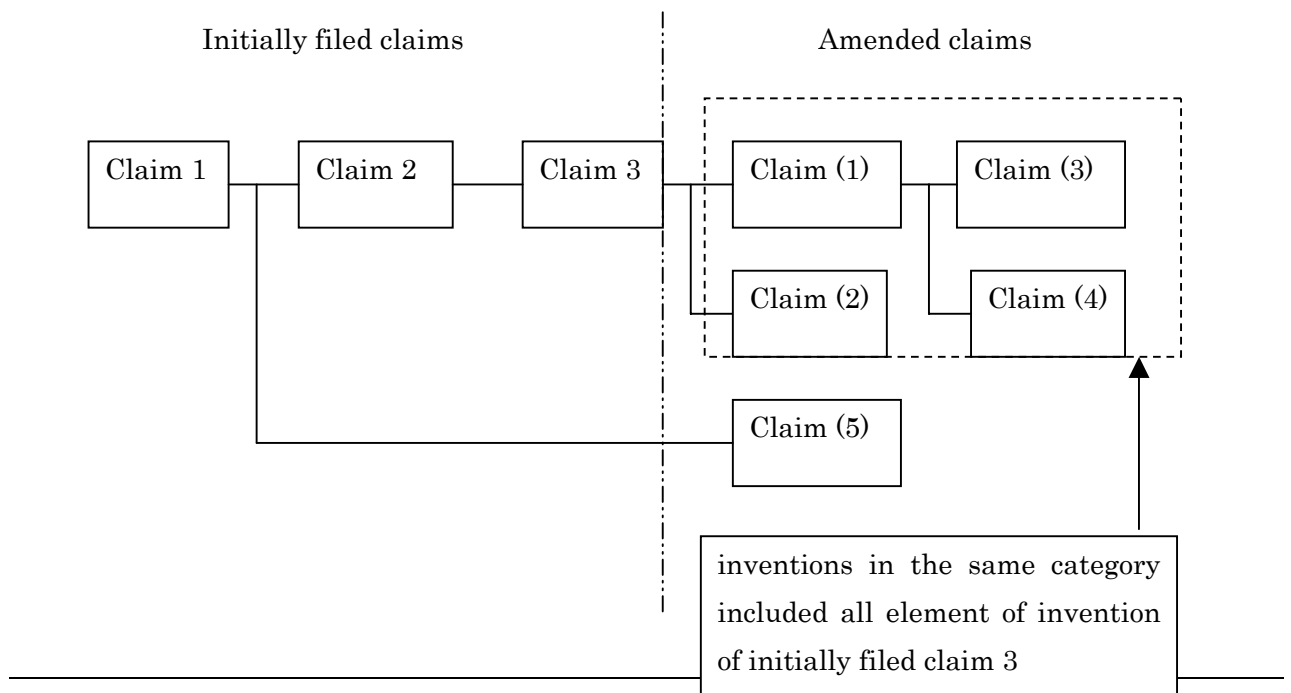

Fig.79

In this case, since the invention according to initially filed claim 3 has special technical features, amended claims (1) - (4) including all of the invention elements of the claim

3 are examined. On the other hand, since the amended claim (5) does not include a part of the invention elements of initially filed claim 3, it is not examined, and an Office Action is issued.

Q80. Amendments Challenged by Third Parties

Can amendments be challenged by third parties? How and when?

A80. (1) Before "KOKAI" Publication

A patent application in Japan is automatically laid open to public inspection as a "KOKAI" publication after the lapse of 18 months from the filing date or, in the case of a patent application with a convention priority, from the priority date. Before the "KOKAI" publication, no one can have access to the official file. Therefore, third parties cannot challenge any amendments filed in relation to the application during this period.

(2) After "KOKAI" Publication and before grant of patent.

After a patent application is KOKAI-published and a KOKAI-publication thereof is issued, anyone can inspect the file wrapper and furnish the Examiner with necessary information in writing. The information which a third party can submit includes not only prior art serving to negate the novelty or inventive step of the invention, but also information on an amendment of the specification or drawings including new matter introduced after the filing of the application. The applicant is informed of the fact that information has been submitted. Whether or not the submitted information has been considered in the examination will be reported to the party who submitted the information, if the party informs the JPO to that effect. Since the party who submitted the information is not engaged with the examination, he or she is unable to communicate with the Examiner by means of, e.g., an interview.

Under the Patent Law, the applicant can amend the specification and/or drawings at any time until a first Office Action is issued from the JPO.

(3) After granting of a patent

After a patent has granted, anyone can initiate a procedure of Invalidation Trial. Through the procedure of the Invalidation

Trial, the plaintiff of the Trial can challenge the amendments made by the applicant during prosecution.

Interview

Q81. Interview Recommended

Is the interview process the recommended procedure to expedite examination?

A81. Yes, the interview with the Examiner is the recommended procedure to expedite examination. It is very effective to hold an interview with the Examiner at any stage to obtain a result favorable to the applicant. It is recommendable to have a interview after fully discussing with a Japanese patent attorney how to proceed.

Q82. Recommended Strategy

Assume you have a case of critical importance to your client. What strategy do you recommend?:

- a. Seek an early interview with Examiner?**
- b. If so, do you wait until after First Office Action or should you try to see the Examiner before the Examiner studies the case and perhaps forms adverse opinion?**
- c. What about preferred or acceleration examination (if conditions met)?**

A82. In such a case, we recommend seeking an interview with the Examiner in charge.

An Examiner is to conduct an interview with respect to an application on which the Examiner has started or is about to start the examination, while an Examiner is not to conduct an interview with respect to the following applications:

- An application for which a request for examination has not been filed;
- An application which has not reached the time for initiating

the examination;

- An application for which a decision of granting a patent has been drafted and approved within the JPO; and

- An application for which a Decision of Rejection has been drafted and approved within the JPO (an application under reconsideration by the Examiner before the examination in the Appeal Board is excluded).

In view of the current interview practice with the Examiner described above, you are advised to wait until after the Examiner's first Office Action is issued.

IV. INFRINGEMENT

Claim Interpretation

Q83. How does the Japanese court interpret the claim, as compared with the U.S. court where the claim interpretation is performed by studying the patent specification, claim language and prosecution history before the Patent and Trademark Office? In Japan, are there any factors affecting the claim interpretation; for example, how about the following factors? :

(a) Object of the invention;

(b) Advantages;

(c) Specifics of the preferred embodiments?

A83. (1) In assessing whether the claim reads on the accused product or process, the first recourse the court considers is the explicit claim language under Art.70(1) of the Patent Law. However, if the claim language is indefinitely vague and ambiguous, the court can consult the specification and the drawings, wherein the court may consider the object, advantages and/or individual embodiments. Basically, the essence of the claimed invention is not in the object and/or advantage but in the structure. On December 26, 1991 in the "Lightweight Coated

Paper Case”, the Tokyo Appellate Court held, in favor of the plaintiff (patentee), that the accused product was different in its objective from the patent’s but had the same technical features as those recited in the claims.

(2) The defendants often try to defend themselves by insisting that their product or process achieves no such advantages expected by the patent, but the advantages mentioned in the specification are not intended to delimit the invention. They are arbitrary predictions rather than facts, lacking the objectivity. The alleged advantages should be distinguished from “industrial applicability (utility)” as one of the requirements for patentability.

(3) The specific embodiments or examples are generally given for illustration purpose, and not considered to restrict the scope of the invention, except when the claim language is unreasonably broad beyond the description. The excessively broad scope of the claim will be contrary to the policy of the patent system where a patent is given in return for disclosure of the invention to the public. In cases where the scope of the claim is indefinite in light of the embodiments and/or prior art, the defendant often refers to the prosecution history.

Q84. The Emphasis of Advantageous Effect may narrow the scope of the invention.

Is this correct?

A84. Art.70(1) of the Patent Law stipulates that the technical scope of a patented invention must be determined according to the description of the claim. Art.70(2) stipulates that the claim language can be interpreted by referring to the body of the specification and drawings. In principle, however, no advantages are permitted to be described in the claims; if they are described in the claims, they may be ignored at the court. If the claim language is too indefinite and obscure, the court may consider the advantages in making claim interpretation. Judicial court judges may read potential structural elements

underlying the claimed invention through the advantages. However, such cases are very rare. (Osaka Appellate Court, decided on November 22, 2002, Case No. H13(ne) 3840)

Q85. The Doctrine of Equivalents

The U.S. patent attorneys have a general impression that Japanese claim interpretation is narrow. Have Japanese courts adopted the doctrine of equivalents, and the doctrine of file wrapper estoppel?

A85. In view of the fact that Japan adopts a statutory law system, and therefore every statute is supreme as the primary legal source, Art.70 of the Patent Law is absolute. Judicial judges were rather hesitant to adopt the doctrine of equivalents to find infringement beyond the letter of the claim. In fact, until 1998 the courts had never held an infringement under the doctrine of equivalents. However, on February 24, 1998, the Supreme Court has provided a guideline in favor of the doctrine of equivalents; that is, the following five requirements must be satisfied for successfully asserting the doctrine of equivalents:

- (1) The part replaced is an insubstantial part of the claimed invention;
- (2) The replacement of the part achieves the object of the claimed invention and produces no unexpected result;
- (3) The replacement of the part would have been obvious to a skilled person at the time of making the accused product (the time of infringement);
- (4) The accused product was novel and non-obvious at the time when the application was made, which means that the accused product could be patentable; and
- (5) There is no proof showing that the applicant intentionally excluded the accused product from the claimed invention during the prosecution. This requirement corresponds to the file wrapper estoppel

established in the U.S. Courts (see Warner-Jenkinson Co. v. Hilton Davis Chem. Co. (1997))

Q86. What will matter if the allowed claim reads as having a different scope from that of the pre-examined published claim?

Alpha Co.'s patent application was published in a pre-examined state after 18 months from the filing date. One structural feature of the invention was not recited in the claim, and as far as the published claim is concerned, it reads on prior art. Beta Co. so read the claim and has started to market their product. Alpha sent a warning letter to Beta, telling that Beta's continued activity may be developing into an unpleasant legal proceeding. However, in response to an office action, Alpha amended the claim to recite the feature in the claim, and eventually obtained allowance on the amended claim.

a. If Beta's product falls outside the scope of the pre-examined published claim but has fallen within the allowed claim, is Alpha entitled to sue Beta?

b. If Beta's product infringes both claims, can Alpha enjoin Beta from continuing the production and recover damages from Beta according to the first published claim?

A86.a. Alpha is entitled to recover damages from Beta on the allowed claim, and also entitled to an injunction. However, Alpha cannot recover damages on the basis of the pre-examined published claim.

A86.b. Alpha is entitled to claim compensation for Beta on the basis of the pre-examined claim, wherein the compensation is equivalent to a probable royalty, only if Alpha showed a copy of the published application and warned Beta to stop their activity. In this respect, the Patent Law was revised in 1999, and provides in Art.64-2 (1) that the applicant can request the earlier publication than 18 months, thereby extending the period of obtaining compensation.

Q87. Doctrine of Claim Differentiation

Does Japan have a doctrine of claim differentiation or its equivalent?

A87. This doctrine is not familiar to us; in our understanding this doctrine is a presumption created when different words or phrases are used claim by claim, and these claims are presumed to have a different scope.

Japan has no doctrine of differentiation or its equivalent. Instead, the Patent Law provides in Art.36(5) that separate claims in one application can be directed to substantially the same invention. However, this provision is intended to guide claim drafting but not to govern claim interpretation.

Q88. Any Influence by Reference Numerals in Claims

It is common practice in European applications to include reference numerals in the claims. How about in Japan:

a. Is it advisable to include reference numerals in the claims?

b. What will be the impact of reference numerals on claim interpretation?

c. Do reference numerals in the claims function as a limitation to the scope of the claims or a file wrapper estoppel?

d. Is the addition of reference numerals to the claims mandatory?

e. Is there any court decision where the reference numerals in the claims became an issue?

A88.a. It will be advisable to include reference numerals in the claims, especially when the claimed invention is complicated. They are intended to help readers understand the claim structure.

A88.b. Reference numerals in the claims do not influence the scope of the claim.

A88.c. Reference numerals in the claims are not regarded as limitation or not considered to constitute file wrapper estoppel.

A88.d. The use of reference numerals is not mandatory.

A88.e. There is no court decision where the presence of reference numerals in the claim was at issue.

Infringement

Q89. Averting an Infringement Action/Compulsory License

Can a Japanese company avert an infringement action by obtaining an improvement patent for a corresponding license under the infringed patent?

A89. There is a relevant provision regarding a dependent patent compulsory license in the paper titled "Actions to be taken by the JPO" attached to a letter of August 16, 1994 addressed from the JPO to the USPTO in exchange of a letter of the same date addressed from the USPTO to the JPO attached with the paper titled "Actions to be taken by the USPTO". The provision describes:

Other than to remedy a practice determined after judicial or administrative process to be anti-competitive or to permit public noncommercial use, after July 1, 1995, the JPO is not to render an arbitration decision ordering a dependent patent compulsory license to be granted.

Accordingly, a patentee of a dependent patent cannot expect to obtain compulsory license pursuant to the Patent Law Art.92 unless either of the above identified conditions is satisfied.

Q90. Remedies for Patent Infringement

What kind of remedies is available for patent

infringement in Japan?

A90. In regard to civil remedies for patent infringement, it is possible to seek an injunctive order, demand damages, demand restitution for unjust enrichment, and seek measures for recovery of reputation.

a. Injunctive Order

A patentee can require a person who is infringing or is likely to infringe the patent right to discontinue or refrain from such infringement under the Patent Law Art.100.

b. Demanding Damages

A patentee can demand damages from a person who has intentionally or negligently infringed the patent right. However, it is generally difficult to prove lots of facts in order to demand damages. Therefore, the Patent Law provides some articles such as Art.102 (presumption of amount of damage), Art.103 (presumption of negligence), Art.104 (presumption of manufacture by patented process), Art.105 (production of documents).

c. Demanding Restitution for Unjust Enrichment

A patentee could demand restitution for unjust enrichment from a person who has infringed the patent right under certain circumstances.

d. Measures for Recovery of Reputation

Upon the request of a patentee, the court can order a person who has damaged a patentee's business reputation to take measures to recover the damaged reputation under the Patent Law Art.106.

Q91. Proof of Infringement of a Method Claim

How can patentee show infringer's working of a "method" claim?

A91. A patentee should prove the fact that a method claim is infringed by an alleged infringer. This proof may be made, for example, by analysis of the infringing products (i.e., the use

of the claimed method which uses a certain chemical might be proved by the fact that the chemical is contained in the final products), and in the court procedure, by the request for documents, or examination by the court of the infringing process at the factory provided that a preliminary proof is made by the plaintiff or patentee, or the statements of witnesses.

In the case that the claimed method concerns a method of manufacture of a new material, which had not been known in Japan before filing the application of the patent, it will be presumed that the infringing products are manufactured by the use of the claimed method pursuant to the Patent Law Art.104.

V. GENERAL (OTHERS)

Q92. Cultural Differences Underlying Patent Practice

What are the most common and/or worst mistakes a U.S. practitioner can make in directing prosecution or litigation of a case in Japan? To what degree do you believe cultural or attitudinal differences contribute to such mistakes?

A92. One common problem concerns differences between the scope of the invention, as supported by actual data or other information in the specification, and the claims. In Japan, a patent right is conferred only for a scope which is reasonable on the basis of what is actually invented by an inventor. The practice of substantive examination and claim interpretation reflects this philosophy which comes from a preference for a third party's interests. In the course of the examination, an Examiner bears in mind what the scope of the claimed invention should be. For examination in the chemical field:

The claims are subject to strict examination in the light of concrete examples or embodiments provided in the specification and applications are often rejected on the ground that the claims are too broad judging from the scope of the disclosed examples or embodiments. In this respect, Examiners

seldom compromise.

However, it was not true particularly in the other technical fields' examination. As long as the sufficient description was made in the specification to explain that the broader scope is capable of providing the purposed meritorious effects, the broad scope was patented even in the case there is only one or a few examples disclosed in the specification. Accordingly, many differences are rather superficial and such differences could be overcome by careful communication with the Examiner.

Another point is that the U.S. practitioners tend to concern about estoppel. The fact in Japan is, there is almost no estoppel between separate cases as long as the examination in the JPO is concerned, the Examiner seldom concern about what the applicant asserts in its separate applications. However, the court might consider the patentee's statement in its separate applications as necessary provided that these applications relate to quite similar subject.

Q93. The JPO Database

Does the public have access to the JPO database information prior to publication of an application?

A93. No, the JPO database has only published information in store, i.e., the secrecy of information prior to publication is always maintained, while it is of course possible for the public to have access to the JPO database to obtain published information. Thus, the JPO database is one of the most convenient tool for obtaining information published even though there is a time-lag for the information to be in store.

**QUESTIONS AND ANSWERS
REGARDING JAPANESE PATENT PRACTICE**

FIRST EDITION 1993

1992 AND 1993 US/JAPAN PATENT PRACTICE COMMITTEE

SECOND EDITION 1998

1996 AND 1997 INTERNATIONAL ACTIVITIES COMMITTEE THIRD GROUP

THIRD EDITION 2007

2007 INTERNATIONAL ACTIVITIES CENTER

JAPAN PATENT ATTORNEYS ASSOCIATION

3-4-2 Kasumigaseki Chiyoda-ku Tokyo 100-0013, JAPAN

<http://www.jpaa.or.jp/>